

DÜSTERLOH **Fluidtechnik**

Pneumatic- motors

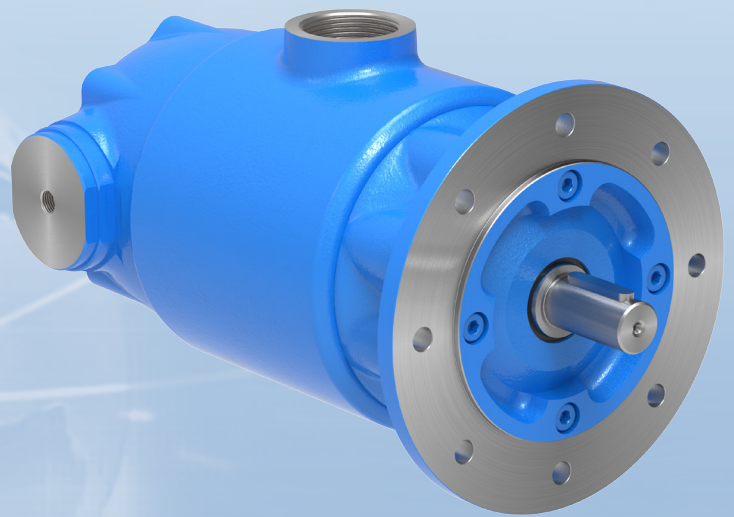

Pneumatic- motors
Pneumatic- gear- motors
Model series PMW

Catalogue

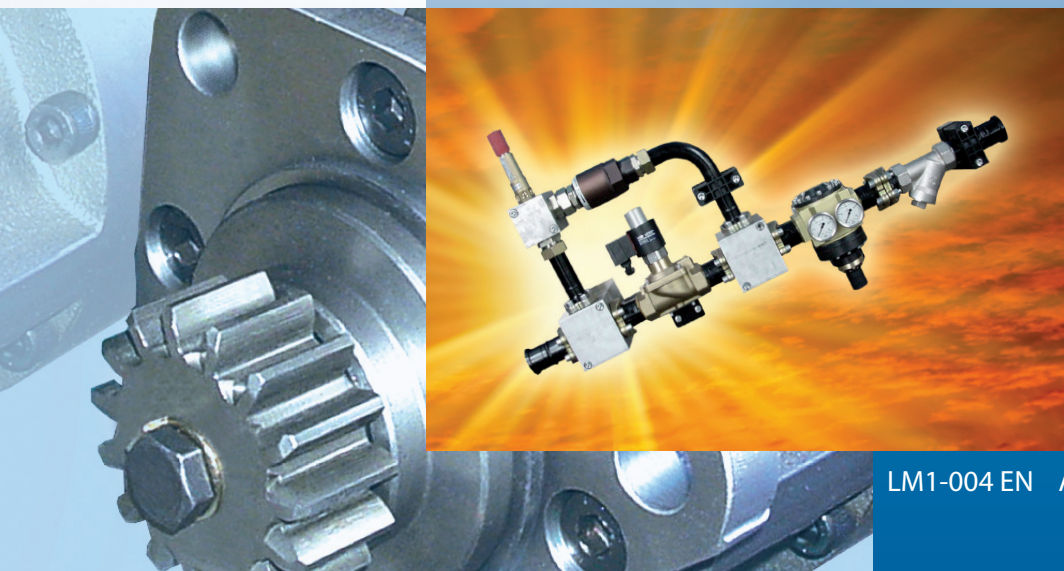

Applications for DÜSTERLOH FLUID TECHNIK Pneumatic-motors PMW.....	3
Pneumatic-motorsDescription, funtion.....	4
Order key for pneumatic-motors PMW	5
Types of control for pneumatic-motors	6
Pneumatic-motors PMW 160 Technical data, Power curves	8
Pneumatic-motors PMW 160 Basic version, Exhaust collar.....	9
Pneumatic-motors PMW 160 Exhaust thread, Version „W“	10
Pneumatic-motors PMW 160 manual reversing	11
Pneumatic-motors PMW 250 Technical data, Power curves	12
Pneumatic-motors PMW 250 Basic version, Exhaust collar.....	13
Pneumatic-motors PMW 250 Exhaust thread, Version „W“	14
Pneumatic-motors PMW 250 manual reversing	15
Pneumatic-motors PMW 400 Technical data, Power curves	16
Pneumatic-motors PMW 400 Basic version, Exhaust collar.....	17
Pneumatic-motors PMW 400 Exhaust thread, Version „W“	18
Pneumatic-motors PMW 400 manual reversing	19
Pneumatic-motors PMW 530 Technical data, Power curves	20
Pneumatic-motors PMW 530 Basic version, Exhaust collar.....	21
Pneumatic-motors PMW 530 Exhaust thread, Version „W“	22
Pneumatic-motors PMW 530 manual reversing	23
Pneumatic-motors PMW 710 Technical data, Power curves	24
Pneumatic-motors PMW 710 Basic version, Exhaust collar.....	25
Accessories: Silencer, Speed regulation	26
Accessories: Drive-off flange, Foot execution.....	27
Accessories: Spring operated multi disk crake LB42.....	28
Order key for pneumatic-motors with planetary gear	29
Generell information of pneumatic gear-motors with planetary gear.....	30
Possible combinations: PWM - Flange - Gearbox versions.....	31
PMW 160 with planerary gear Technical data.....	32
PMW 160 with planerary gear Versions - Dimensions	33
PMW 250 with planerary gear Technical data.....	34
PMW 250 with planerary gear Versions - Dimensions	35
PMW 400 with planerary gear Technical data.....	36
PMW 400 with planerary gear Versions - Dimensions	37
PMW 530 with planerary gear Technical data.....	38
PMW 530 with planerary gear Versions - Dimensions	39

-
- | | | | |
|----------|---|----------|---|
| A | Air conditioner drivers
Aluminum melting furnaces
Anchor winches
Auger drives | M | Mining plants
Mixer drives
Mixing plants
Mooring winches |
| B | Bending machines
Blind shaft reel drives | P | Paper machines
Pilot hoists
Pipe cleaning devices
Pipeline main pusher drives
Pre-lubrication pump drives
Pump drives |
| C | Capstan winches
Caterpillars
Chain conveyors
Charging plants
Chemical mixers
Claw winches
Coal cutters
Coke emitting machines
Cold-compressor drives
Concrete mixers
Concrete pumps
Convert-drives
Convert-flap drives
Conveyor belts
Conveyor machines
Core hole drills
Crane trains | R | Raw iron mixers
Reel drives
Rotary tables
Rotation drives
Rudder machines |
| D | Derricks
Drills
Drive helps
Driving drives | S | Scraper winches
Servo drives
Servomotor drives
Ship winches
Starters
Steering aid
Stone drill machines
Stowing machines
Swimming docks
Swivel machines |
| F | Fountain-drill devices | T | Track laying machines
Transport trolley drives
Trolley drives |
| H | Hatch cover actuation
Hauling engines
Hydraulic pumps | U | Underwater drives |
| L | Lance stroke devices
Lifting devices
Lifting winches
Loading machines | V | Vehicles winches |
| | | W | Winch drive
Winding machines |



Take a closer look at our Pneumatic Motors...

- Speed setting by easy thottle control.
- Change of direction by way-valves with manual or remote control.
- Higher start-torque than rated torque.
- Save in damp atmosphere and extreme climatical conditions.
- With oiler for permanent operation and for operations in damp air.
- Works with gas, air, nitrogen.
- Special construction for operation with unooled air.
- Time-unlimited overload also at stand still.
- Particularly suitable for operation in explosive environment.
- Robust construction garantuees high operation safety
- Long lifetime due hardened and grinded rotors.
- Good silencing due long exhaust ways. Additional silencers are available.
- IEC flange- and shaft dimensions according DIN 42677, exchangeable with electro-motors.
- Waterproofed.

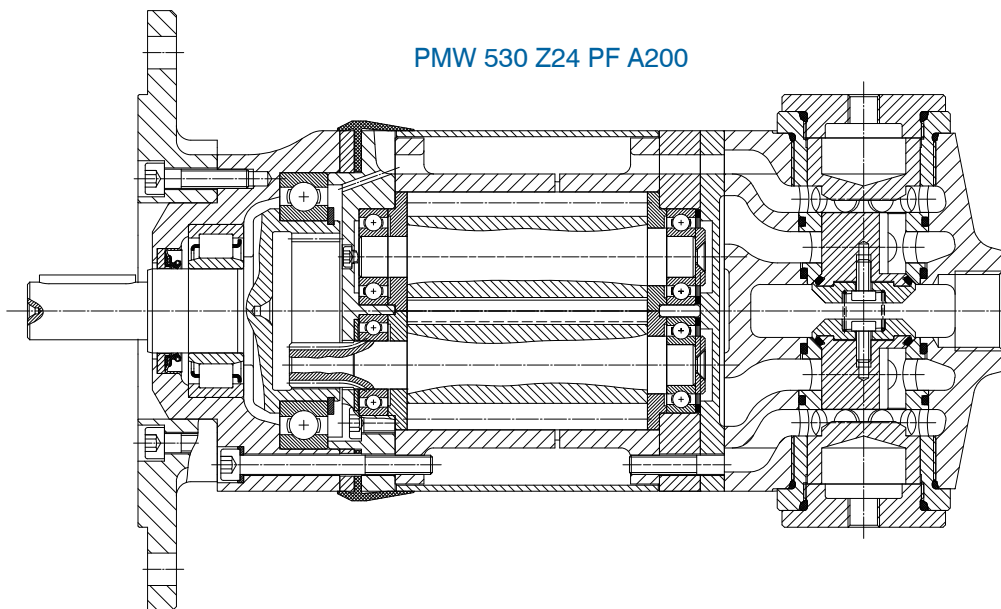

Pneumatic-motor PMW

model	torque T (Nm)	speed range n (rpm)		operating pressure p (bar)		nominal power P (kW)	nominal air consumption Q (Nm ³ /min)
		Nominal	maximal*	nom.	maximal		
PMW 160	9	3000	4000*	6	10	2,8	3,9
PMW 250	15	3000	4000*	6	10	4,7	6,0
PMW 400	22	3000	4000*	6	10	6,9	8,4
PMW 530	27	3000	4000*	6	10	8,5	12,0
PMW 710	35	3000	4000*	6	10	11	15,0

* Maximum allowable speed, in relation to bearing, by running at no-load.

Principle of function

Series PMW 160 - PMW 710

Throughh different steering-covers, the compressed air powered two straight toothed steelrotors, which are fitted in a casted housing with bearing for permanent operation. At the output side the drive rotor runs in a gearwheel of a beared and sealed output shaft; by gear reduction, the roter speed is reduced. The extended air escapes throughh the exhaust air seal into the environment or will be go along the exhaust air thread. To avoid corrosion in damp air, an oiler is recommended.



item	designation	remark
1	pneumatic-motor PMW EL / ER	To achieve full motor performance, the following air source connection sizes are (supply air pipe) recommended: PMW 160 - PMW 250 = G 1 PMW 400 - PMW 530 = G 1 1/2 PMW 710 = G 2
2	pneumatic-motor PMW ML / MR	
3	pneumatic-motor PMW PF	
4	pneumatic-motor PMW PU	
5	pressure regulator G 3/4 oder G 1	
6	dirt trap G 1 oder G 1 1/2	
7	ball valve G 3/4 oder G 1	
8	control valve G 3/4 oder G 1	
9	3/2 way valve DN 7	
10	oiler G 3/4 oder G 1	
11	4/3 way valve DN 7	
12	4/3 way valve G 3/4 oder G 1	

* By working with damp air, we advise to add an oiler.

1) Motor- implementation: **EL/ER** One rotating direction operation with ball valve item 7

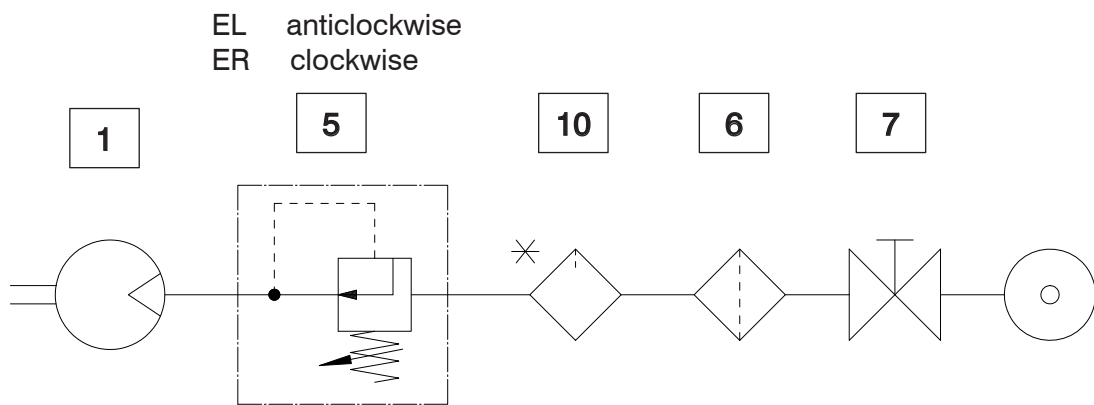

2) Motor- implementation: **EL/ER** One rotating direction operation with way valve item 8 with hand- or elect. pilot control

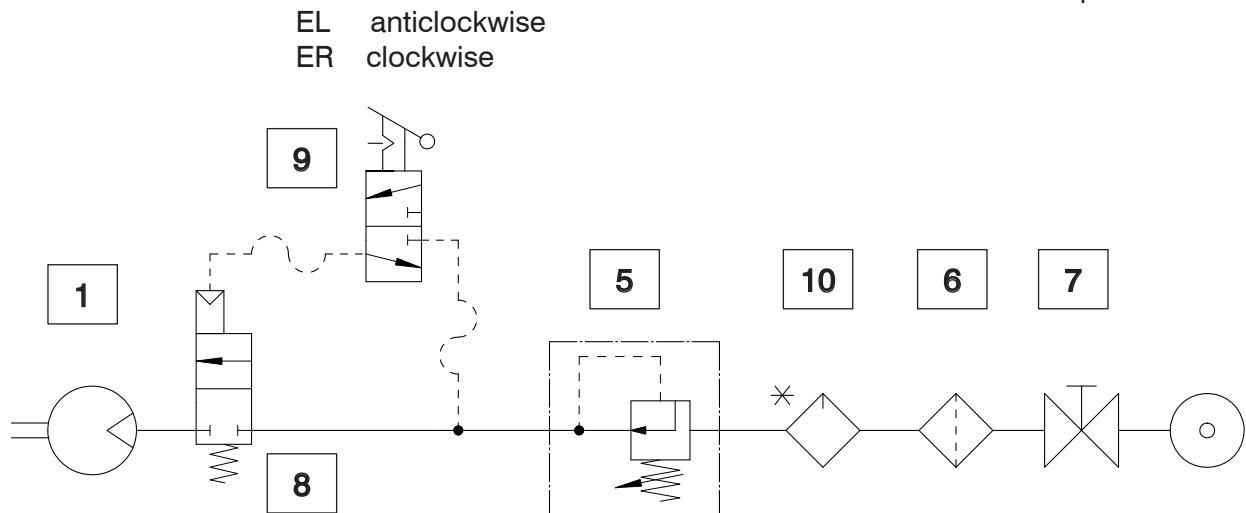

3) Motor- version: **PU**

Two rotating directions

The valve item 12 is operated either electronically or manually by hand.

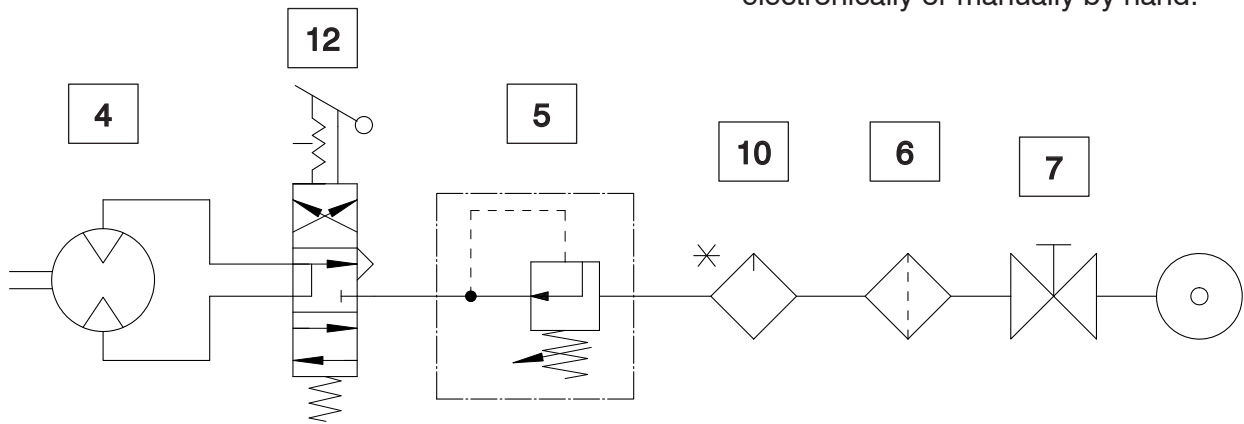

4) Motor- implementation: **ML / MR**

Two rotating directions

with integrated 4/3 way valve and operating by hand.

ML hand lever anticlockwise
MR hand lever clockwise

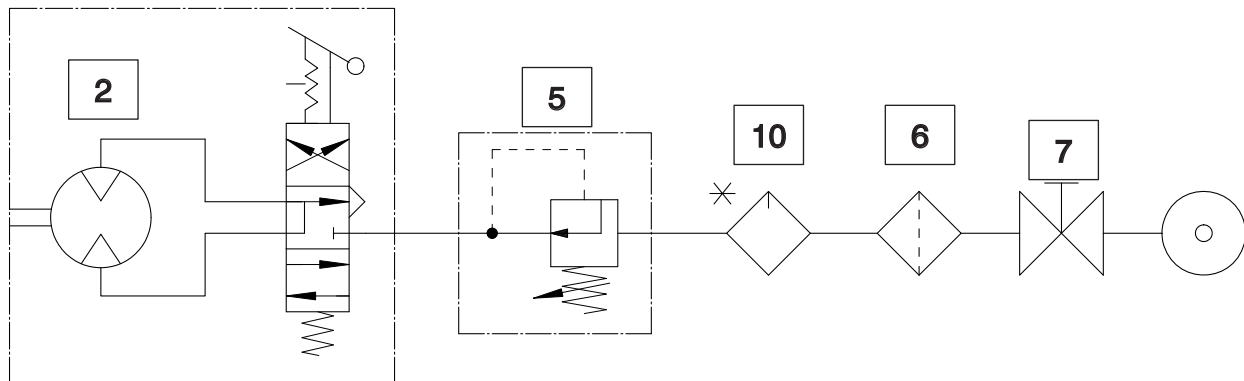

5) Motor- implementation: **PF**

Two rotating directions

with integrated 4/3 way valve and pneumatic remote control.
The external control valve is operated electronically or by hand.

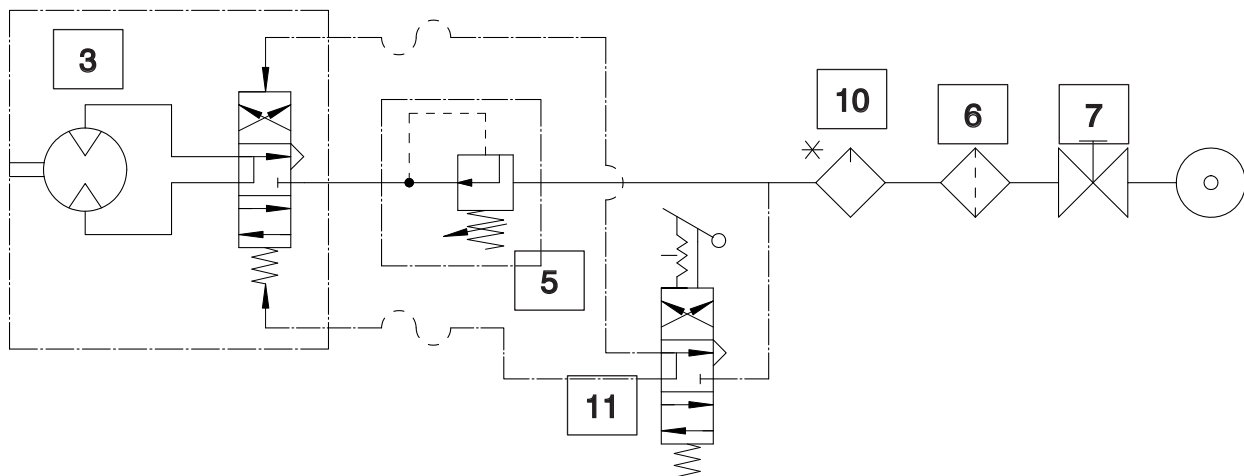

Commissioning and Maintenance Manual look catalog page Nr.: 02.000.087AD

Pressure medium: Compressed air if the compressed air is damped, we recommend to use an oiler!
Nitrogen, natural gas etc. in case of order please indicate the medium!

Mounting position: Any

Sense of rotation: By viewing onto the output shaft, see information in the data sheet!

Control typ: **EL / ER** : A rotation direction is given by a company (EL- simply anticlockwise / ER- simply clockwise).
PU / PU1 : According to pressure connection 1 or 2, direction of rotation anticlockwise or clockwise. PU1 with additional measuring- and impulse- connections, the upcoming operation pressure can be used for measurement and control purposes.
PF : With integrated seat valves according to control p= 3-10 bar, for anticlockwise / clockwise and locking position. By relieving control pressure, automatic locking position.
ML/MR : Hand lever activity control type PF; anticlockwise / clockwise / locking position.

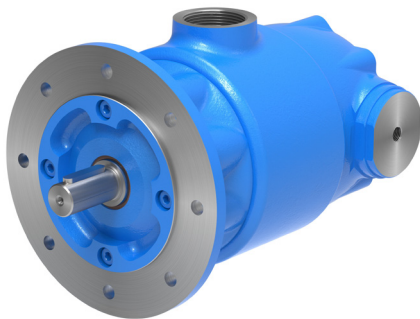

nominal pressure	p_N	=	6	bar
max. operating pressure	p_{max}	=	10	bar
nominal speed	n_N	=	3000	min ⁻¹
max. speed	n_{max}	=	4000	min ⁻¹

Technical data at n=3000 min⁻¹ ; p=6 bar

nominal air consumption	Q_{nom}	=	3,9	Nm ³ /min
nominal torque	T_N	=	9	Nm
nominal power	P_N	=	2,8	kW

The technical data relates to the unthrottled motor, that means without mounted exhaust air throttle, or silencer!

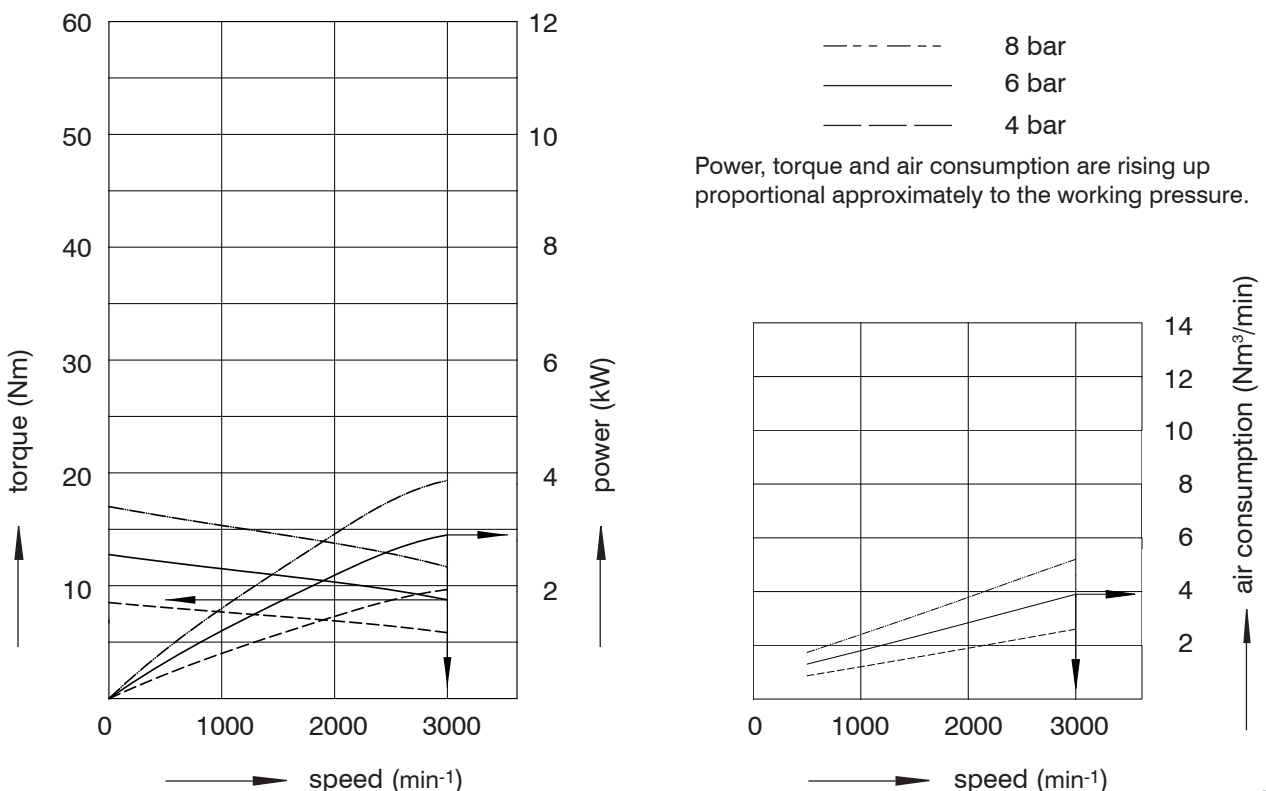

Output shaft: Cylindrical with feather key Z24 / Z28 to DIN 6885

Control: **EL** one direction of motor, anticlockwise
ER one direction of motor, clockwise

weight: 17,5 kg

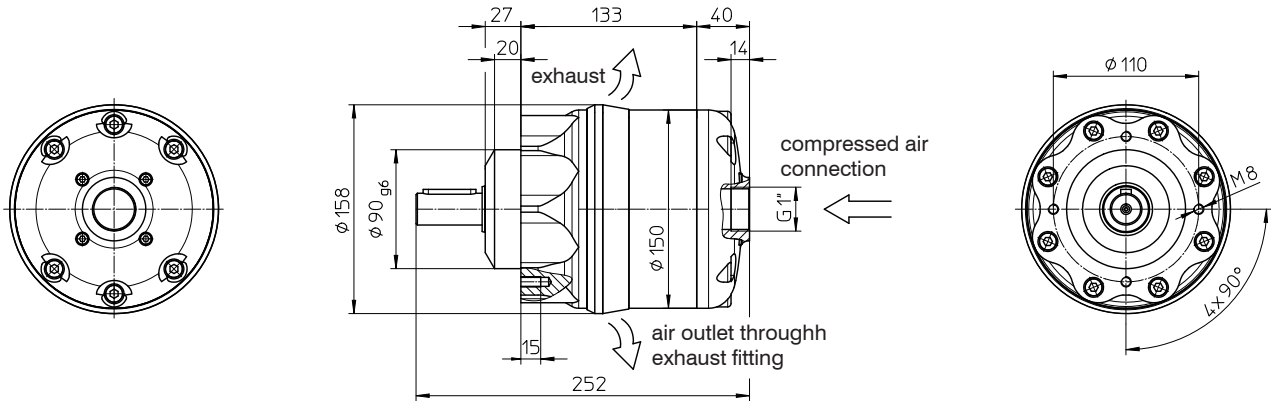

Output shaft: Cylindrical with feather key Z24 / Z28 to DIN 6885

Control: **PU** two directions of motor
PU1 two additional measurements and pulse connections

weight: 21 kg

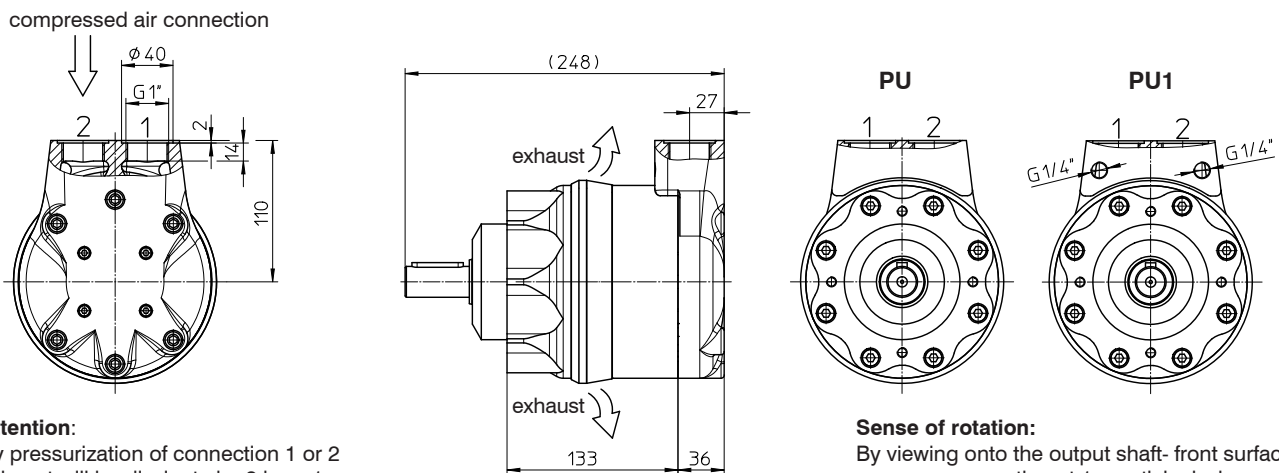

Attention:
By pressurization of connection 1 or 2 exhaust will be dissipate by 2 bzw. 1. The ports may not be closed.

Sense of rotation:
By viewing onto the output shaft- front surface pressure connection at 1: anticlockwise
pressure connection at 2: clockwise

Output shaft: Cylindrical with feather key Z24 / Z28 to DIN 6885

Control: **PF** two directions of motor with locking position

weight: 24 kg

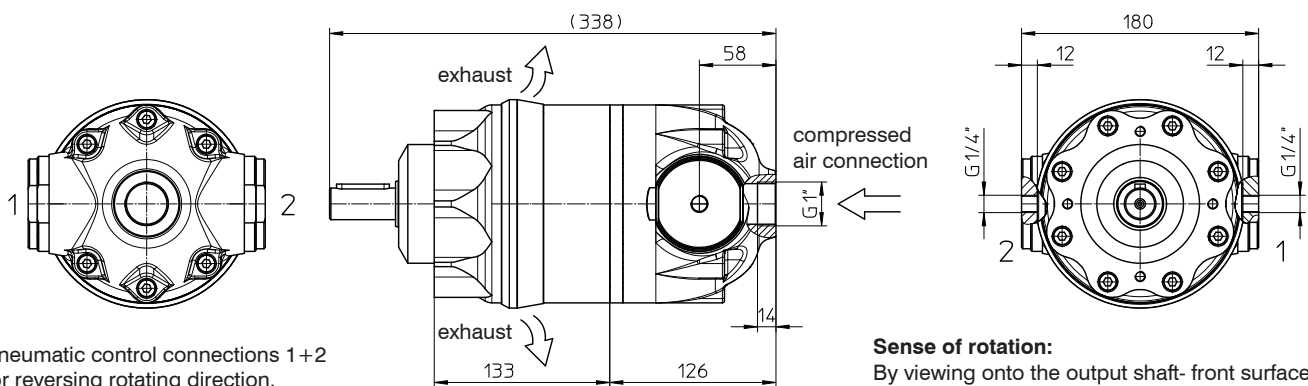

Pneumatic control connections 1+2 for reversing rotating direction. Pressureless: Motor stands still (integrated seat valve is closed).

Sense of rotation:
By viewing onto the output shaft- front surface control pressure at 1: anticlockwise
control pressure at 2: clockwise
No control pressure: locking position



Output shaft: Cylindrical with feather key Z24 / Z28 to DIN 6885

Control: **EL** one direction of motor, anticlockwise
ER one direction of motor, clockwise

weight: 18,5 kg

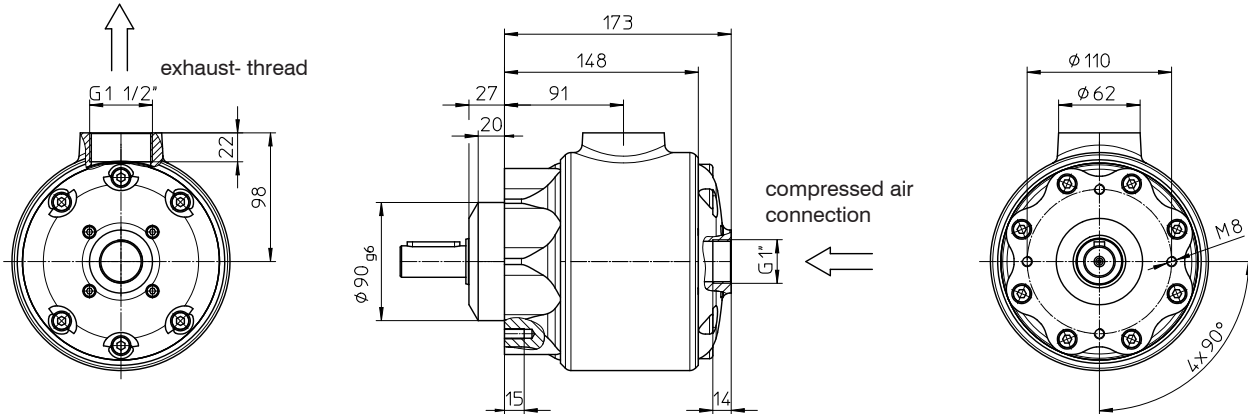

Output shaft: Cylindrical with feather key Z24 / Z28 to DIN 6885

Control: **PU** two directions of motor
PU1 two additional measurements and pulse connections

weight: 22 kg

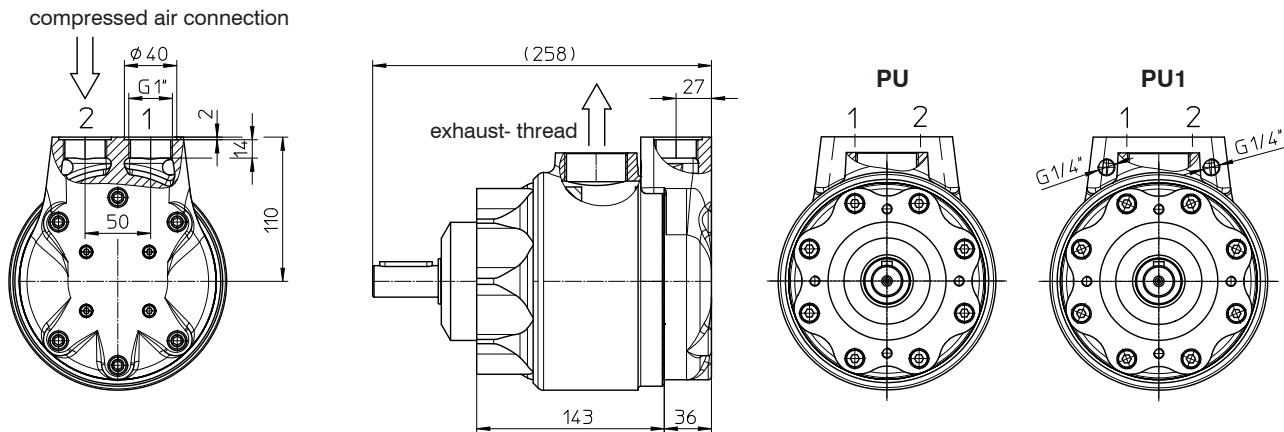

Attention:
By pressurization of connection 1 or 2
exhaust will be dissipate by 2 bzw. 1.
The ports may not be closed.

Sense of rotation:
By viewing onto the output shaft- front surface
pressure connection at 1: anticlockwise
pressure connection at 2: clockwise

Output shaft: Cylindrical with feather key Z24 / Z28 to DIN 6885

Control: **PF** two directions of motor with locking position

weight: 25 kg

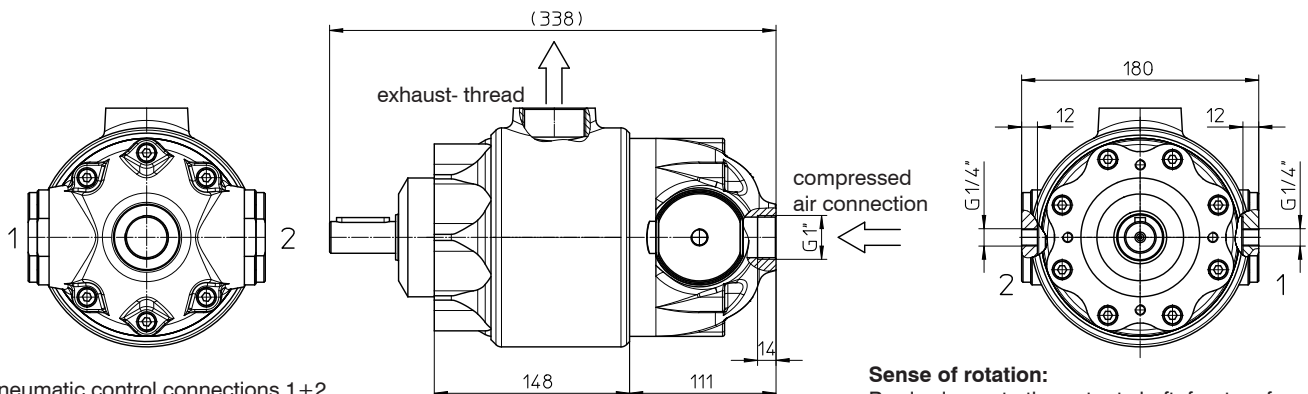

Pneumatic control connections 1+2
for reversing rotating direction.
Pressureless: Motor stands still
(integrated seat valves is closed).

Sense of rotation:
By viewing onto the output shaft- front surface
control pressure at 1: anticlockwise
control pressure at 2: clockwise
No control pressure: locking position



Basic version with exhaust fitting

weight: 24 kg

Output shaft: Cylindrical with feather key Z24 / Z28 to DIN 6885

Control: **ML** two directions at hand lever arrangement left und view onto the air connection.
MR two directions at hand lever arrangement right und view onto the air connection.

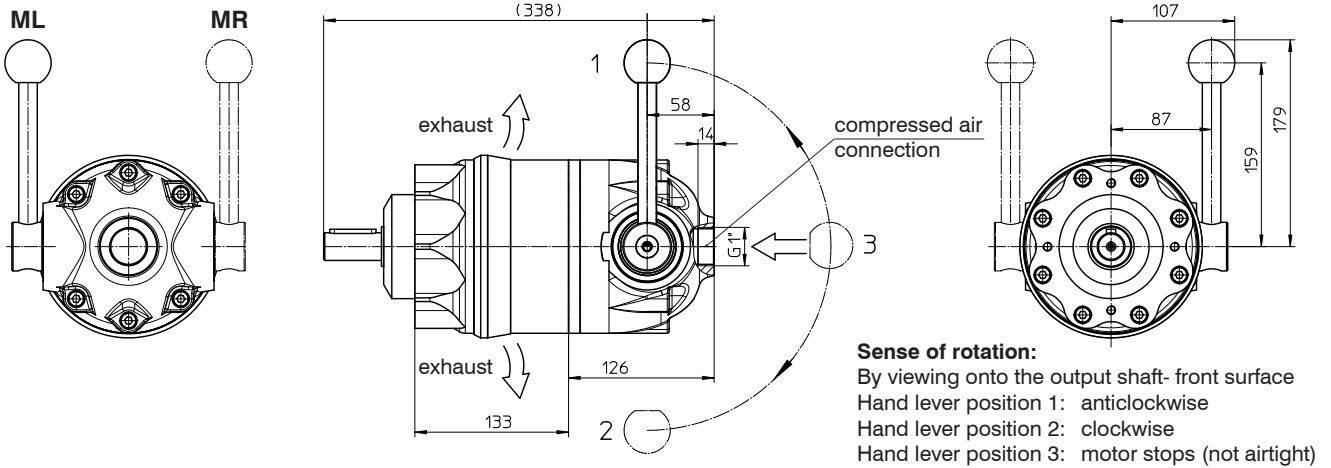

Basic version with exhaust thread, closed implementation „W“

weight: 25 kg

Output shaft: Cylindrical with feather key Z24 / Z28 to DIN 6885

Control: **ML** two directions at hand lever arrangement left und view onto the air connection.
MR two directions at hand lever arrangement right und view onto the air connection.

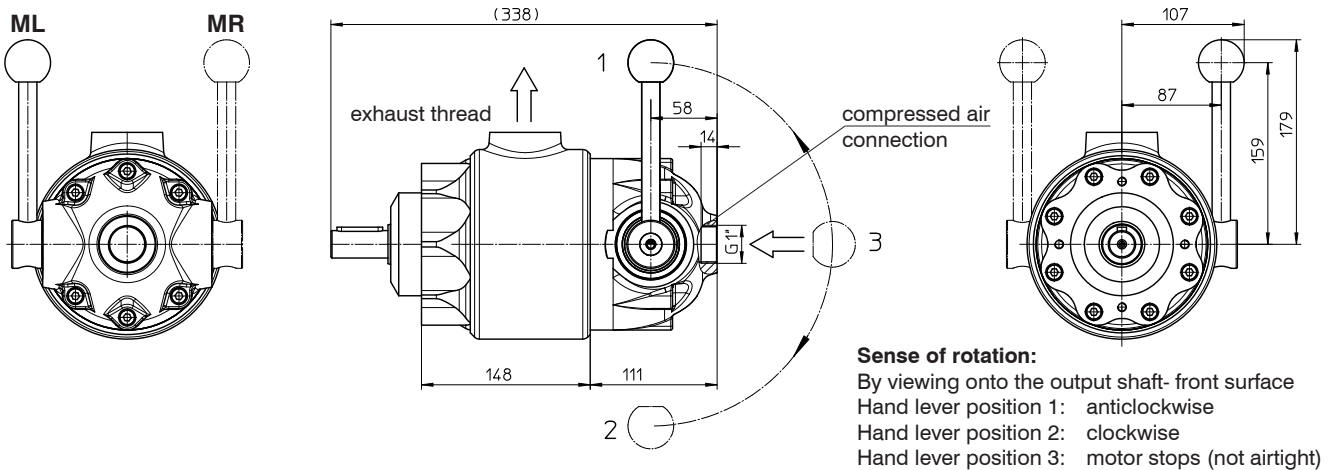

Output shaft implementation

feather key Z24 to DIN6885 A8x7x40

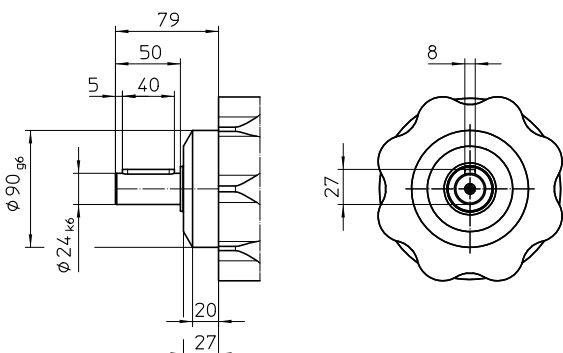

feather key Z28 to DIN6885 A8x7x50

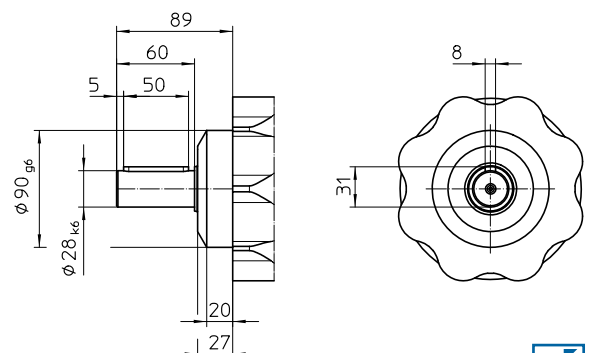

Commissioning and Maintenance Manual look catalog page Nr.: 02.000.087AD

Pressure medium: Compressed air if the compressed air is damped, we recommend to use an oiler!
Nitrogen, natural gas etc. in case of order please indicate the medium!

Mounting position: Any

Sense of rotation: By viewing onto the output shaft, see information in the data sheet!

- Control typ:**
- EL / ER :** A rotation direction is given by a company (EL- simply anticlockwise / ER- simply clockwise).
 - PU / PU1 :** According to pressure connection 1 or 2, direction of rotation anticlockwise or clockwise. PU1 with additional measuring- and impulse- connections, the upcoming operation pressure can be used for measurement and control purposes.
 - PF :** With integrated seat valves according to control p= 3-10 bar, for anticlockwise / clockwise and locking position. By relieving control pressure, automatic locking position.
 - ML/MR :** Hand lever activity control type PF; anticlockwise / clockwise / locking position.

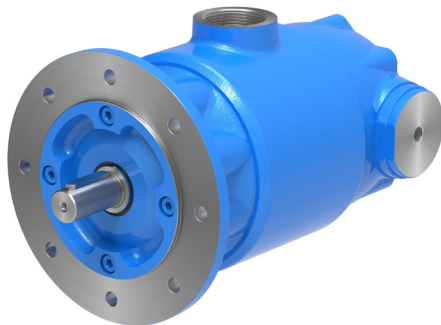

nominal pressure	p_N	=	6	bar
max. operating pressure	p_{max}	=	10	bar
nominal speed	n_N	=	3000	min ⁻¹
max. speed	n_{max}	=	4000	min ⁻¹

Technical data at n=3000 min⁻¹ ; p=6 bar

nominal air consumption	Q_{nom}	=	6	Nm ³ /min
nominal torque	T_N	=	15	Nm
nominal power	P_N	=	4,7	kW

The technical data relates to the unthrottled motor, that means without mounted exhaust air throttle, or silencer!

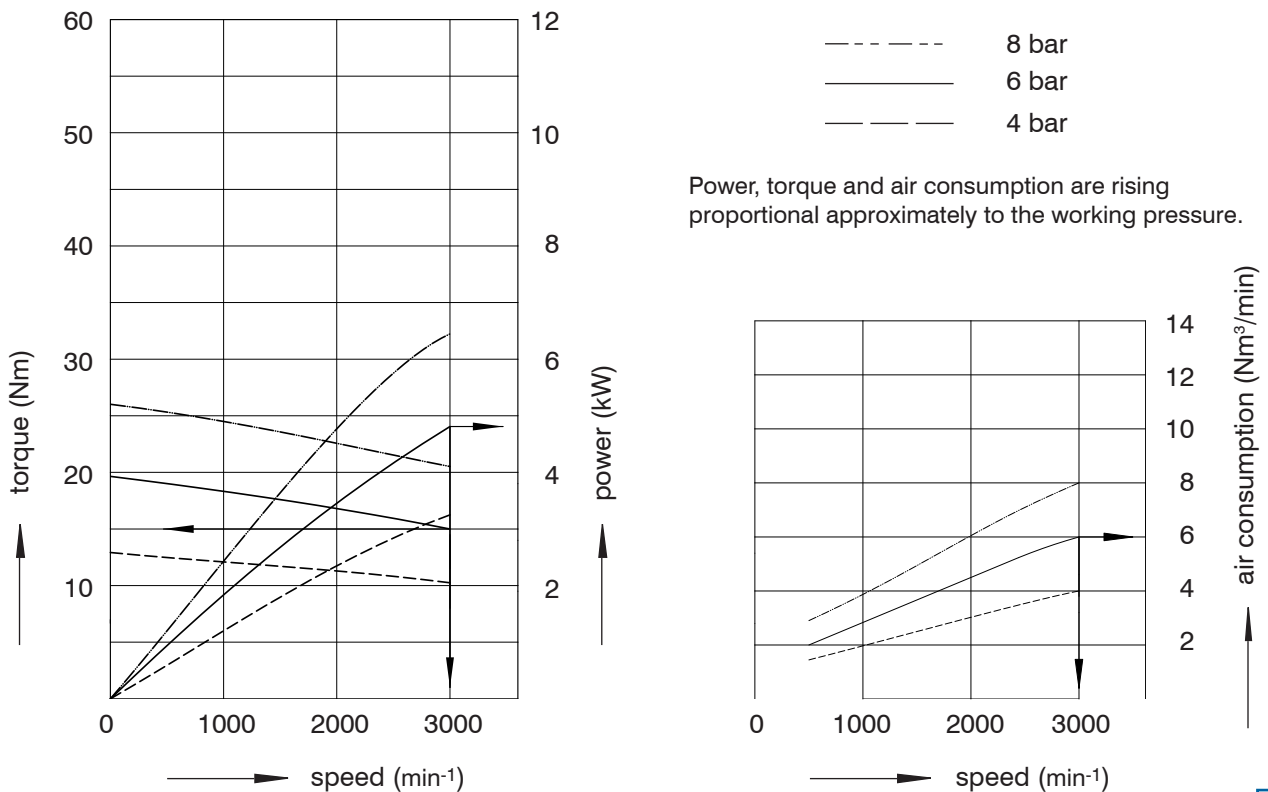

Output shaft: Cylindrical with feather key Z24 / Z28 to DIN 6885

Control: **EL** one direction of motor, anticlockwise
ER one direction of motor, clockwise

weight: 19 kg

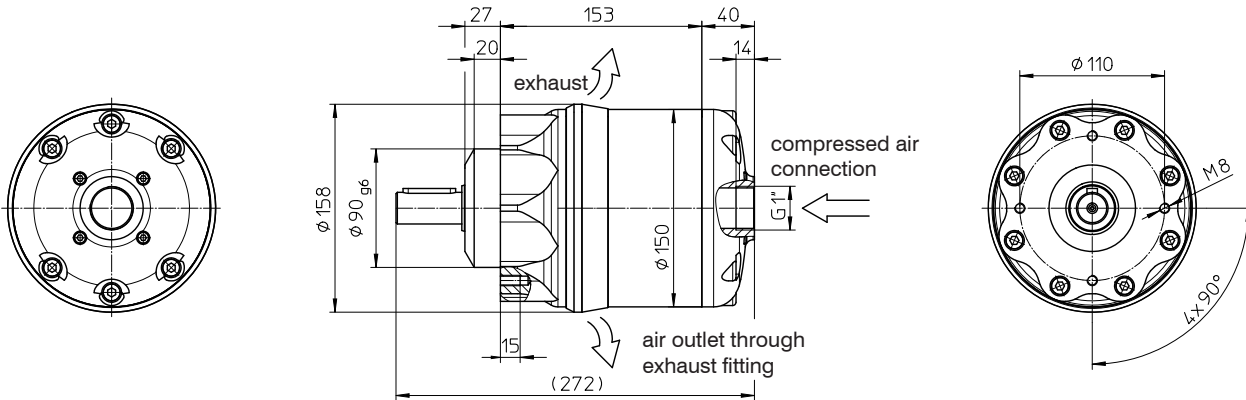

Output shaft: Cylindrical with feather key Z24 / Z28 to DIN 6885

Control: **PU** two directions of motor
PU1 two additional measurements and pulse connections

weight: 22,5 kg

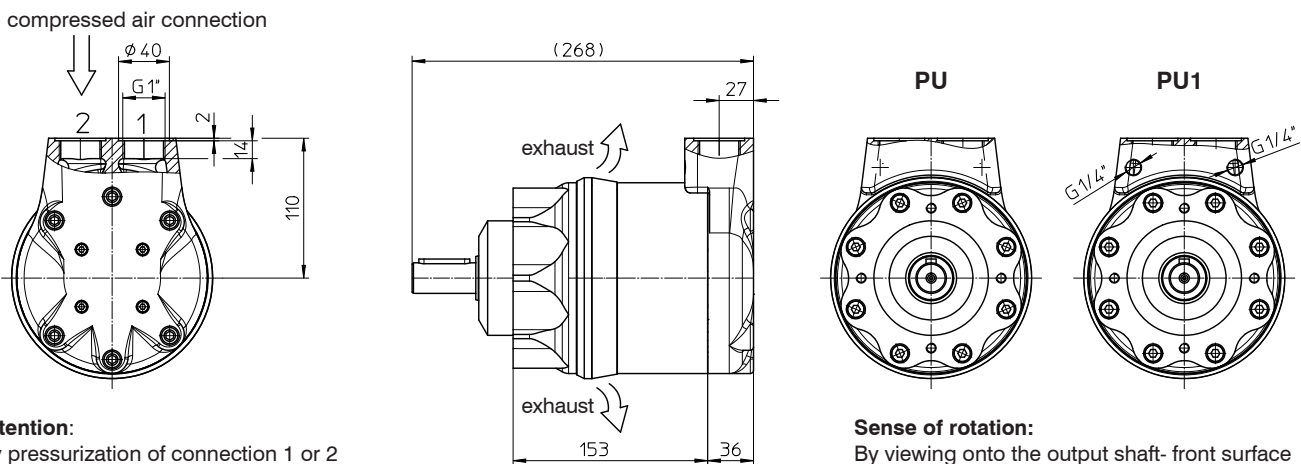

Attention:
By pressurization of connection 1 or 2 exhaust will be dissipate by 2 bzw. 1. The ports may not be closed.

Sense of rotation:
By viewing onto the output shaft- front surface
pressure connection at 1: anticlockwise
pressure connection at 2: clockwise

Output shaft: Cylindrical with feather key Z24 / Z28 to DIN 6885

Control: **PF** two directions of motor with locking position

weight: 25,5 kg

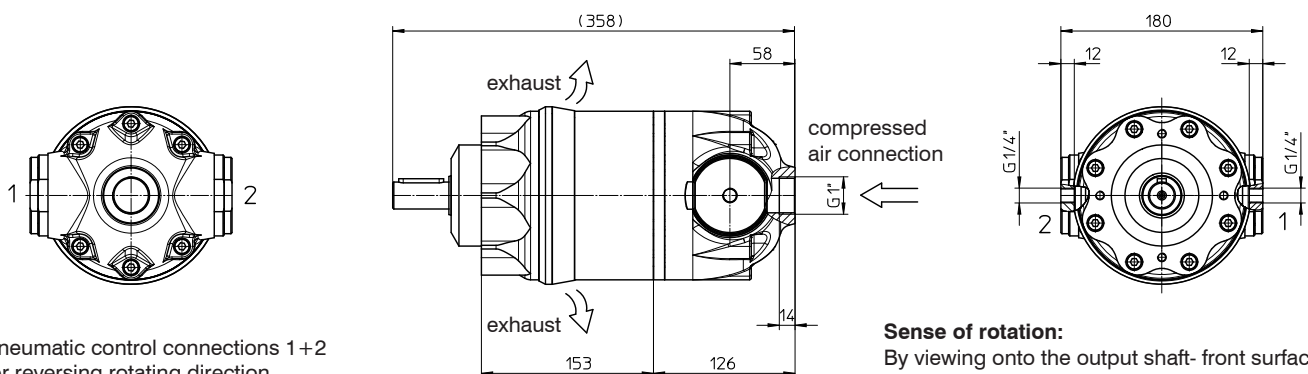

Pneumatic control connections 1+2 for reversing rotating direction. Pressureless: Motor stands still (integrated seat valve is closed).

Sense of rotation:
By viewing onto the output shaft- front surface
control pressure at 1: anticlockwise
control pressure at 2: clockwise
No control pressure: locking position



Output shaft: Cylindrical with feather key Z24 / Z28 to DIN 6885

Control: **EL** one direction of motor, anticlockwise
ER one direction of motor, clockwise

weight: 20 kg

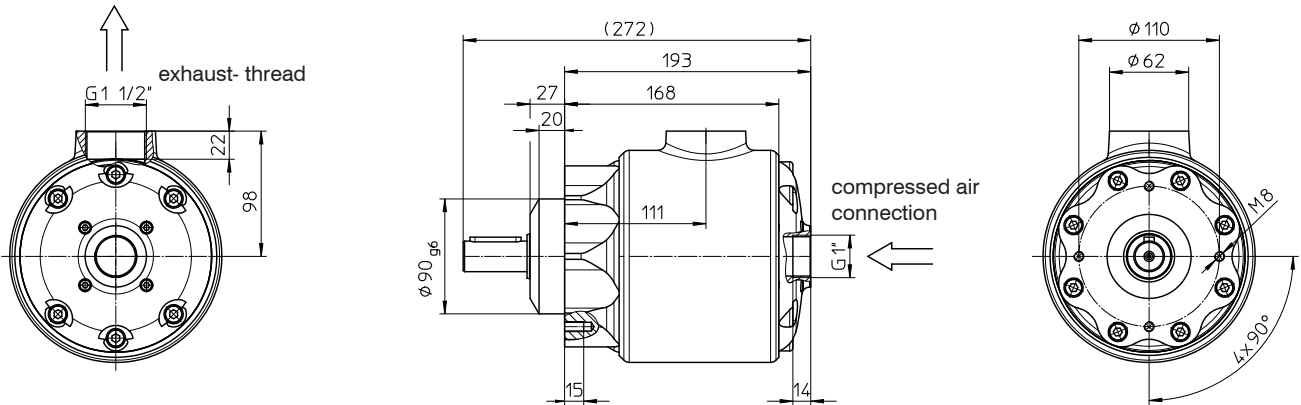

Output shaft: Cylindrical with feather key Z24 / Z28 to DIN 6885

Control: **PU** two directions of motor
PU1 two additional measurements and pulse connections

weight: 23,5 kg

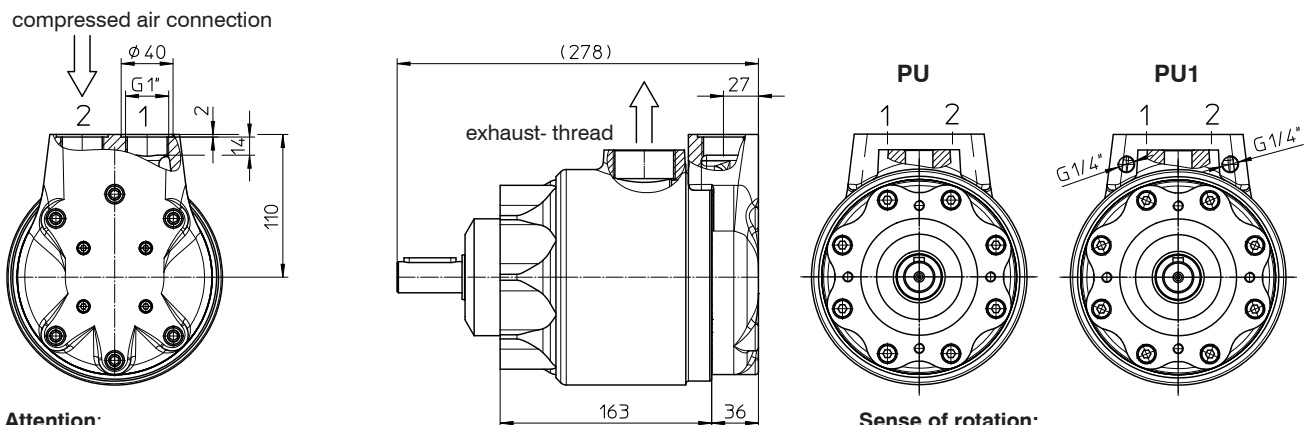

Attention:
 By pressurization of connection 1 or 2
 exhaust will be dissipate by 2 bzw. 1.
 The ports may not be closed.

Sense of rotation:
 By viewing onto the output shaft- front surface
 pressure connection at 1: anticlockwise
 pressure connection at 2: clockwise

Output shaft: Cylindrical with feather key Z24 / Z28 to DIN 6885

Control: **PF** two directions of motor with locking position

weight: 26,5 kg

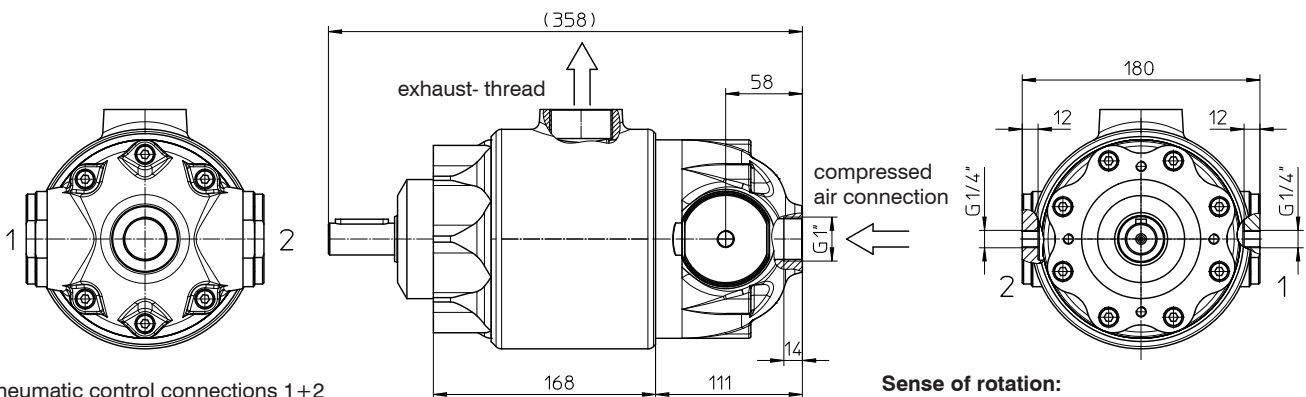

Pneumatic control connections 1+2
 for reversing rotating direction.
 Pressureless: Motor stands still
 (integrated seat valve is closed).

Sense of rotation:
 By viewing onto the output shaft- front surface
 control pressure at 1: anticlockwise
 control pressure at 2: clockwise
 No control pressure: locking position



Basic version with exhaust fitting

weight: 25,5 kg

Output shaft: Cylindrical with feather key Z24 / Z28 to DIN 6885

Control: **ML** two directions at hand lever arrangement left und view onto the air connection.
MR two directions at hand lever arrangement right und view onto the air connection.

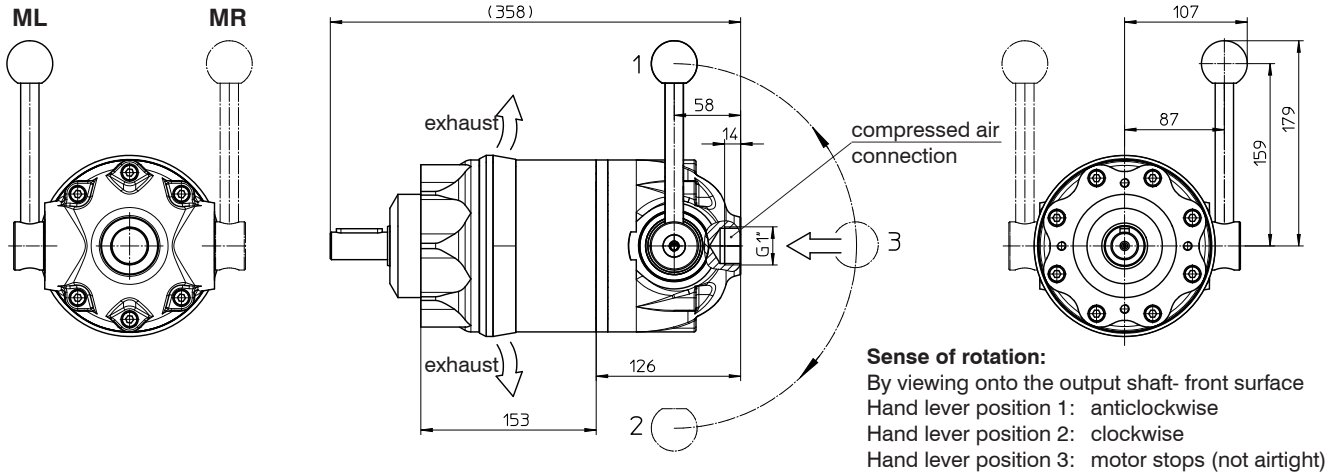

Basic version with exhaust thread, closed implementation „W“

weight: 26,5 kg

Output shaft: Cylindrical with feather key Z24 / Z28 to DIN 6885

Control: **ML** two directions at hand lever arrangement left und view onto the air connection.
MR two directions at hand lever arrangement right und view onto the air connection.

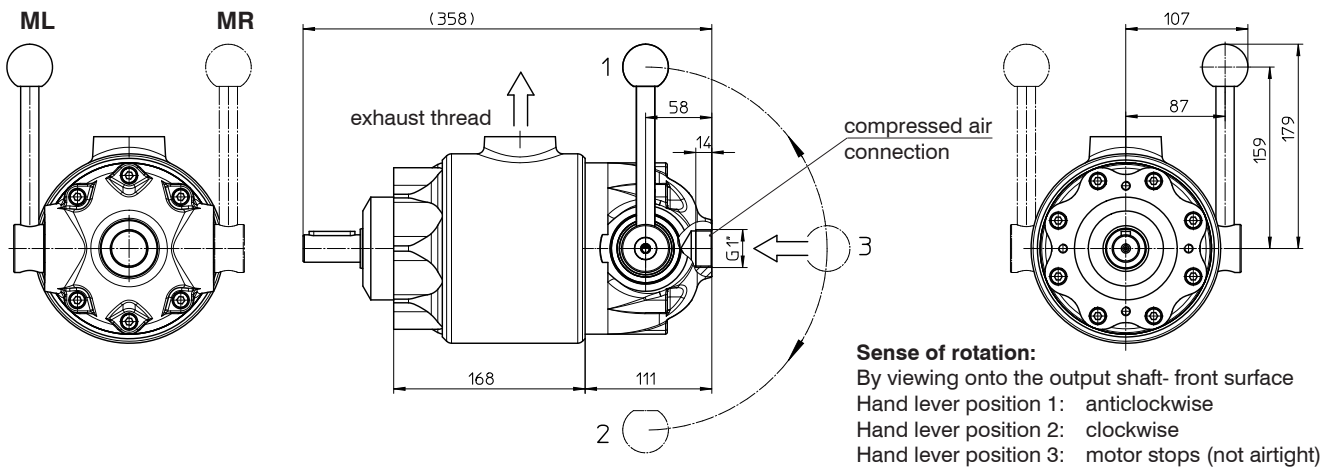

Output shaft implementation

feather key Z24 to DIN6885 A8x7x40

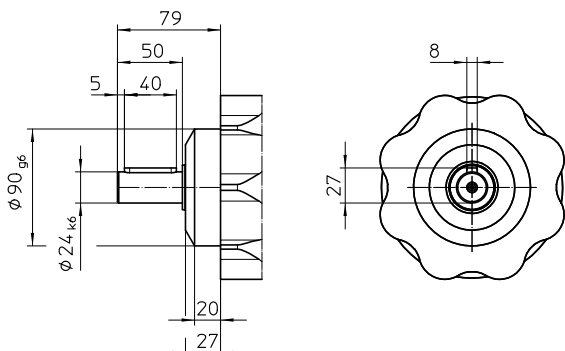

feather key Z28 to DIN6885 A8x7x50

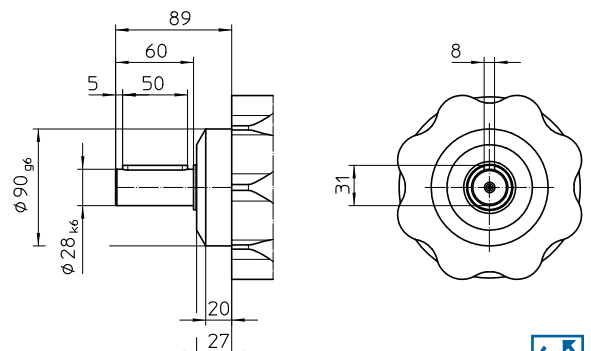

Commissioning and Maintenance Manual look catalog page Nr.: 02.000.087AD

Pressure medium: Compressed air if the compressed air is damped, we recommend to use an oiler!
Nitrogen, natural gas etc. in case of order please indicate the medium!

Mounting position: Any

Sense of rotation: By viewing onto the output shaft, see information in the data sheet!

- Control typ:**
- EL / ER :** A rotation direction is given by a company (EL- simply anticlockwise / ER- simply clockwise).
 - PU / PU1 :** According to pressure connection 1 or 2, direction of rotation anticlockwise or clockwise. PU1 with additional measuring- and impulse- connections, the upcoming operation pressure can be used for measurement and control purposes.
 - PF :** With integrated seat valves according to control p= 3-10 bar, for anticlockwise / clockwise and locking position. By relieving control pressure, automatic locking position.
 - ML/MR :** Hand lever activity control type PF; anticlockwise / clockwise / locking position.

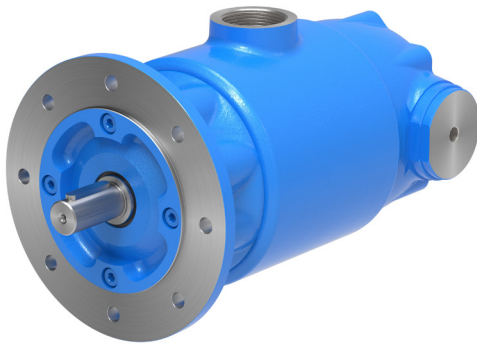

nominal pressure	p_N	=	6	bar
max. operating pressure	p_{max}	=	10	bar
nominal speed	n_N	=	3000	min ⁻¹
max. speed	n_{max}	=	4000	min ⁻¹

Technical data at n=3000 min⁻¹ ; p=6 bar

nominal air consumption	Q_{nom}	=	8,4	Nm ³ /min
nominal torque	T_N	=	22	Nm
nominal power	P_N	=	6,9	kW

The technical data relates to the unthrottled motor, that means without mounted exhaust air throttle, or silencer!

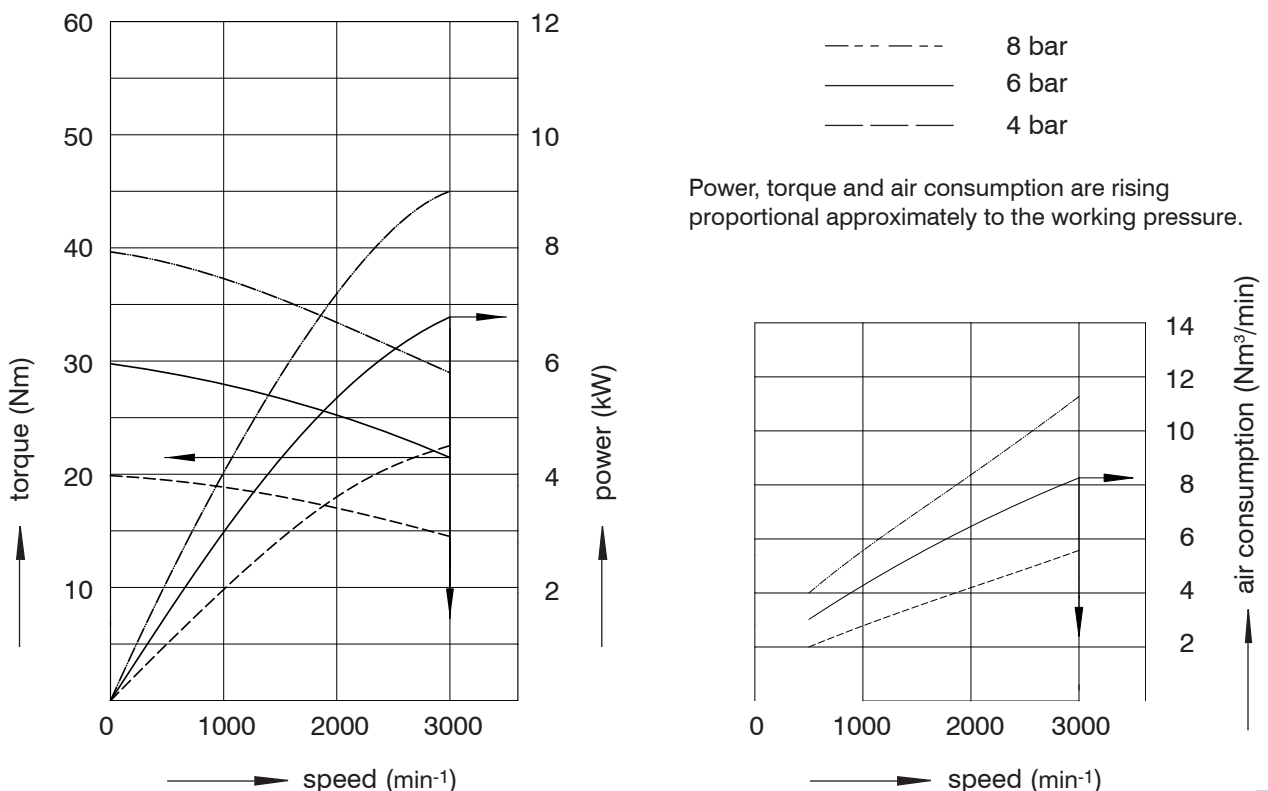

Output shaft: Cylindrical with feather key Z24 / Z28 to DIN 6885

Control: **EL** one direction of motor, anticlockwise
ER one direction of motor, clockwise

weight: 21 kg

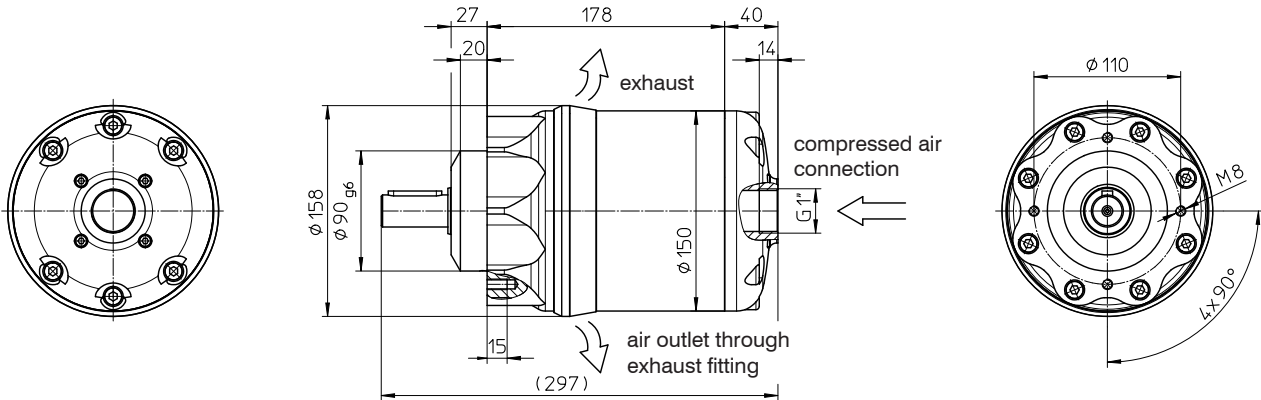

Output shaft: Cylindrical with feather key Z24 / Z28 to DIN 6885

Control: **PU** two directions of motor
PU1 two additional measurements and pulse connections

weight: 24,5 kg

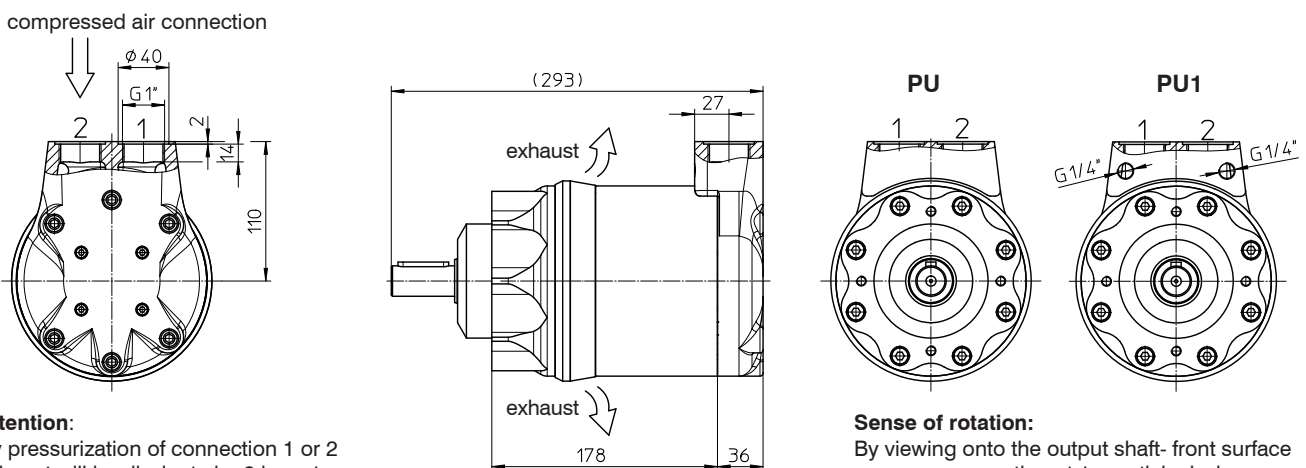

Attention:
By pressurization of connection 1 or 2 exhaust will be dissipate by 2 bzw. 1. The ports may not be closed.

Sense of rotation:
By viewing onto the output shaft- front surface
pressure connection at 1: anticlockwise
pressure connection at 2: clockwise

Output shaft: Cylindrical with feather key Z24 / Z28 to DIN 6885

Control: **PF** two directions of motor with locking position

weight: 27,5 kg

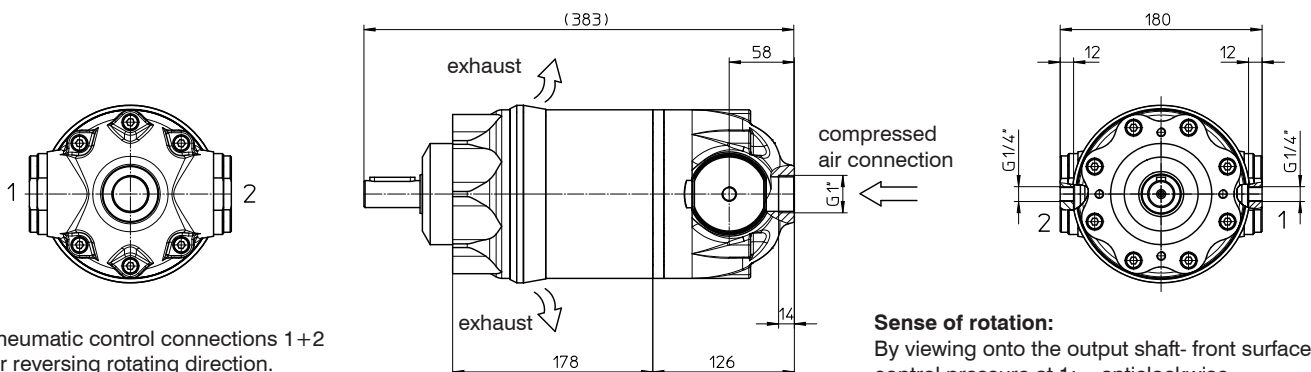

Pneumatic control connections 1+2 for reversing rotating direction. Pressureless: Motor stands still (integrated seat valve is closed).

Sense of rotation:
By viewing onto the output shaft- front surface
control pressure at 1: anticlockwise
control pressure at 2: clockwise
No control pressure: locking position



Output shaft: Cylindrical with feather key Z24 / Z28 to DIN 6885

Control: **EL** one direction of motor, anticlockwise
ER one direction of motor, clockwise

weight: 22 kg

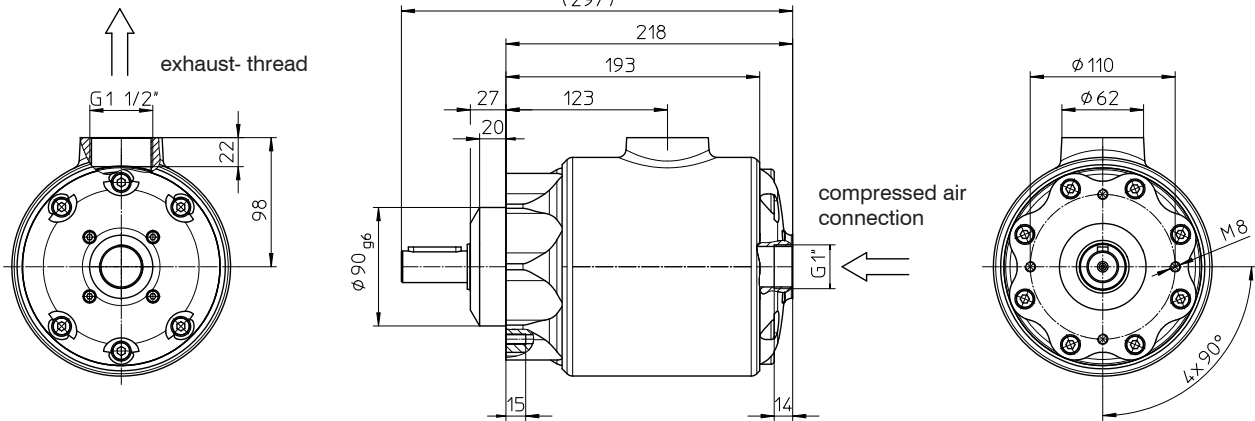

Output shaft: Cylindrical with feather key Z24 / Z28 to DIN 6885

Control: **PU** two directions of motor
PU1 two additional measurements and pulse connections

weight: 25,5 kg

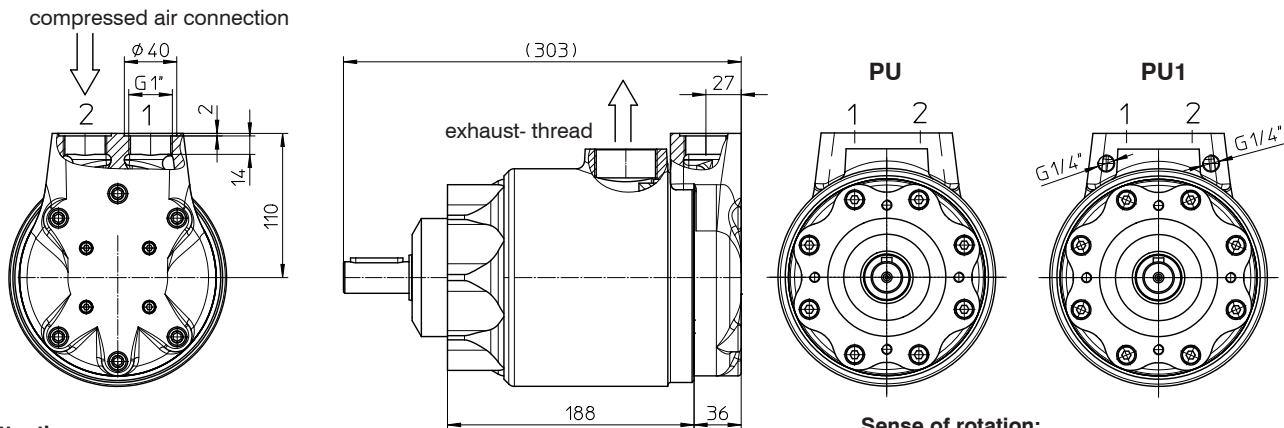

Attention:
By pressurization of connection 1 or 2
exhaust will be dissipate by 2 bzw. 1.
The ports may not be closed.

Sense of rotation:
By viewing onto the output shaft- front surface
pressure connection at 1: anticlockwise
pressure connection at 2: clockwise

Output shaft: Cylindrical with feather key Z24 / Z28 to DIN 6885

Control: **PF** two direction of motor with locking position

weight: 28,5 kg

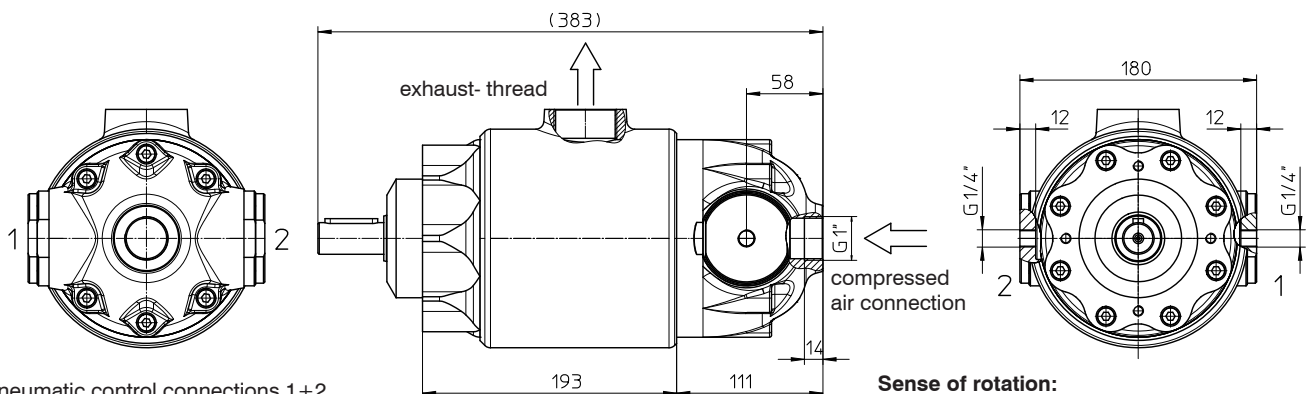

Pneumatic control connections 1+2
for reversing rotating direction.
Pressureless: Motor stands still
(integrated seat valves is closed).

Sense of rotation:
By viewing onto the output shaft- front surface
control pressure at 1: anticlockwise
control pressure at 2: clockwise
No control pressure: locking position



Basic version with exhaust fitting

weight: 27,5 kg

Output shaft: Cylindrical with feather key Z24 / Z28 to DIN 6885

Control: **ML** two directions at hand lever arrangement left und view onto the air connection.
MR two directions at hand lever arrangement right und view onto the air connection.

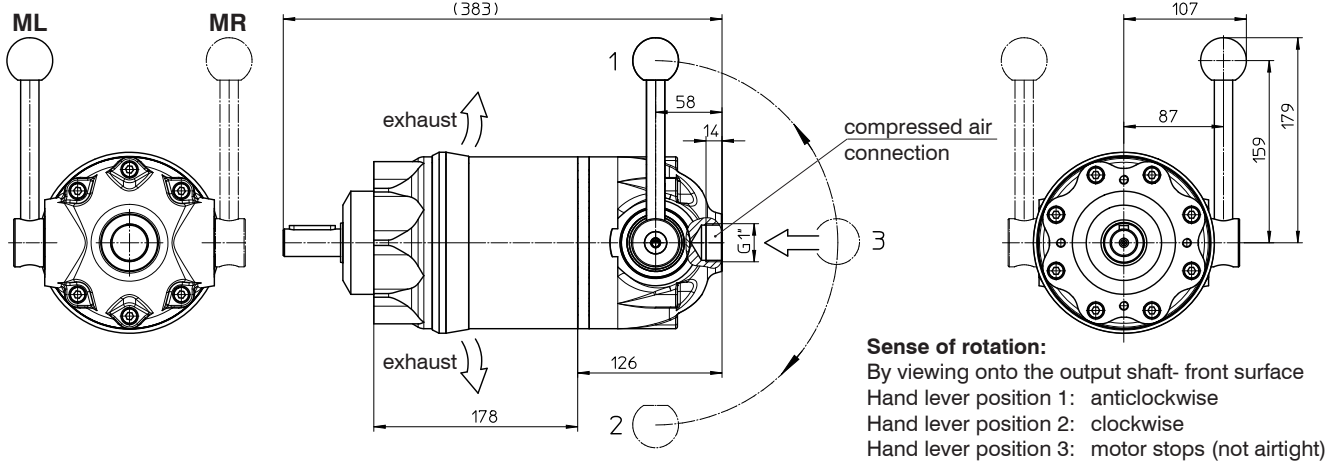

Basic version with exhaust thread, closed implementation „W“

weight: 28,5 kg

Output shaft: Cylindrical with feather key Z24 / Z28 to DIN 6885

Control: **ML** two directions at hand lever arrangement left und view onto the air connection.
MR two directions at hand lever arrangement right und view onto the air connection.

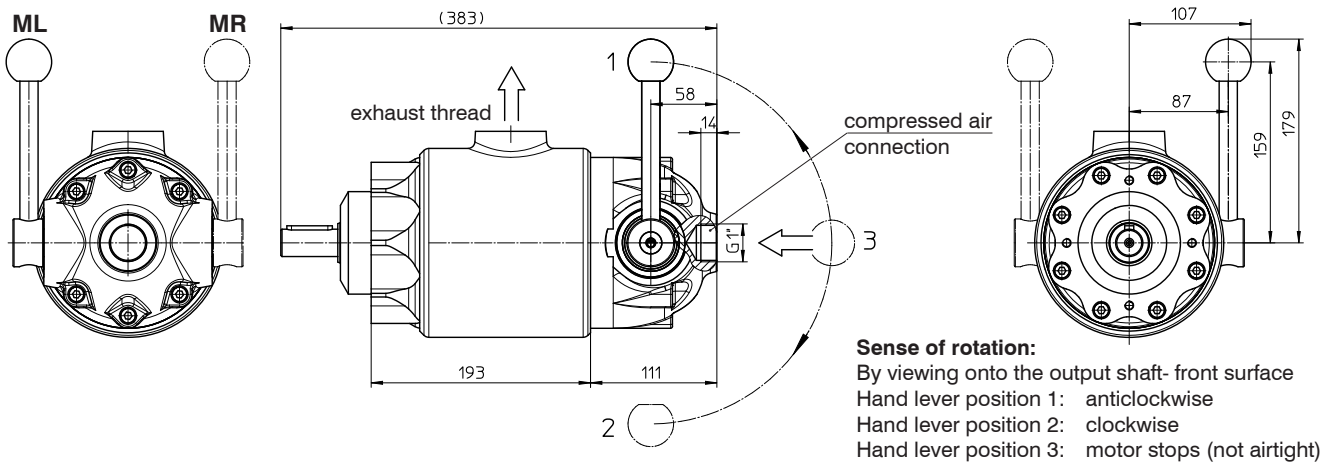

Output shaft implementation

feather key Z24 to DIN6885 A8x7x40

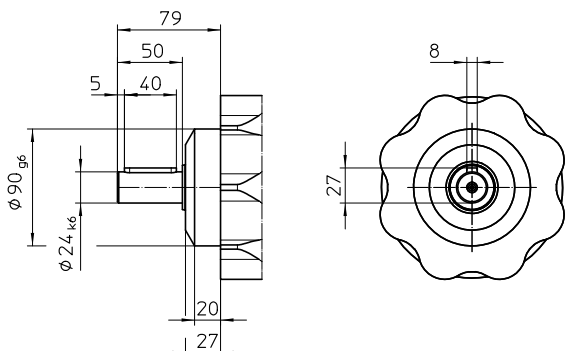

feather key Z28 to DIN6885 A8x7x50

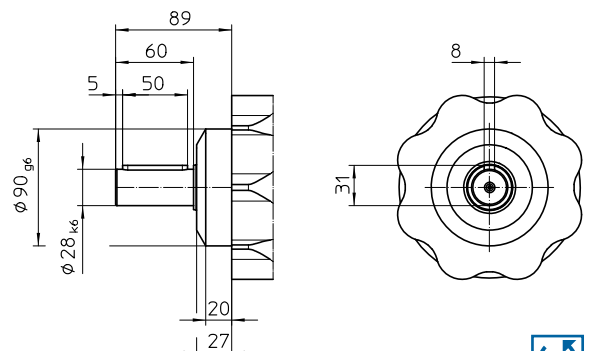

Commissioning and Maintenance Manual look catalog page Nr.: 02.000.087AD

Pressure medium: Compressed air if the compressed air is damped, we recommend to use an oiler!
Nitrogen, natural gas etc. in case of order please indicate the medium!

Mounting position: Any

Sense of rotation: By viewing onto the output shaft, see information in the data sheet!

- Control typ:**
- EL / ER :** A rotation direction is given by a company (EL- simply anticlockwise / ER- simply clockwise).
 - PU / PU1 :** According to pressure connection 1 or 2, direction of rotation anticlockwise or clockwise. PU1 with additional measuring- and impulse- connection, the upcoming operation pressure can be used for measurement and control purposes.
 - PF :** With integrated seat valves according to control p= 3-10 bar, for anticlockwise / clockwise and locking position. By relieving control pressure, automatic locking position.
 - ML/MR :** Hand lever activity control type PF; anticlockwise / clockwise / locking position.

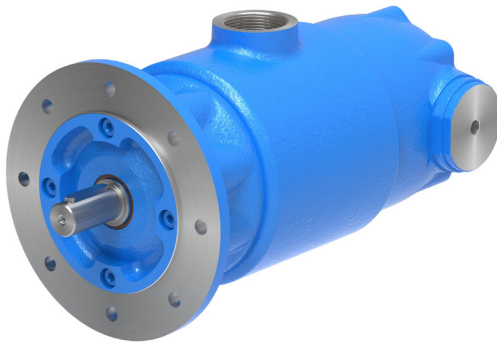

nominal pressure	$p_N = 6$	bar
max. operating pressure	$p_{max} = 10$	bar
nominal speed	$n_N = 3000$	min ⁻¹
max. speed	$n_{max} = 4000$	min ⁻¹

Technical data at n=3000 min⁻¹ ; p=6 bar

nominal air consumption	$Q_{nom} = 12$	Nm ³ /min
nominal torque	$T_N = 27$	Nm
nominal power	$P_N = 8,5$	kW

The technical data relates to the unthrottled motor, that means without mounted exhaust air throttle, or silencer!

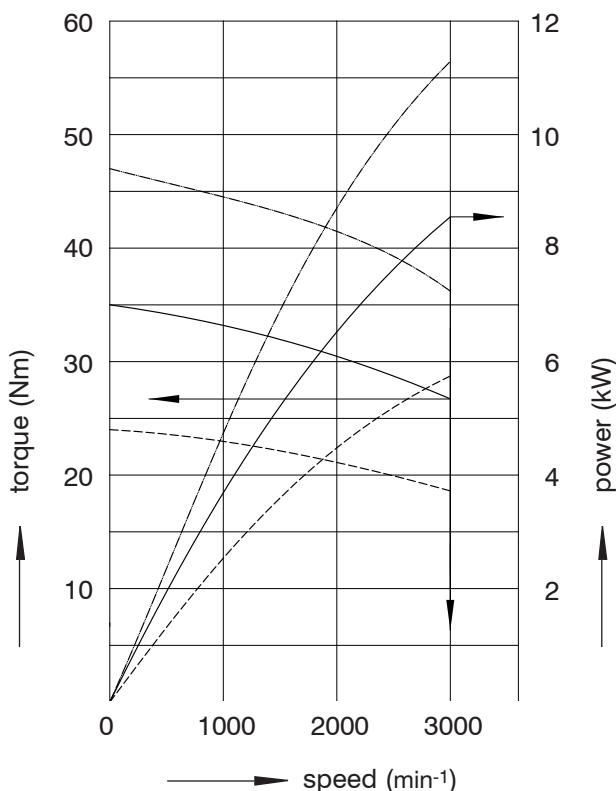

--- 8 bar
— 6 bar
- - - 4 bar

Power, torque and air consumption are rising proportional approximately to the working pressure.

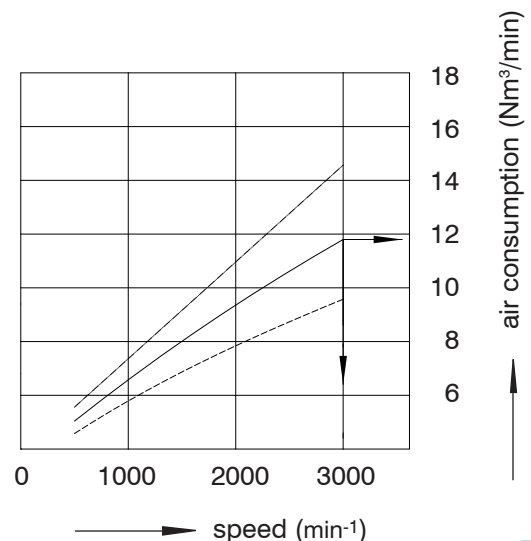

Output shaft: Cylindrical with feather key Z24 / Z28 to DIN 6885

Control: **EL** one direction of motor, anticlockwise
ER one direction of motor, clockwise

weight: 22,5 kg

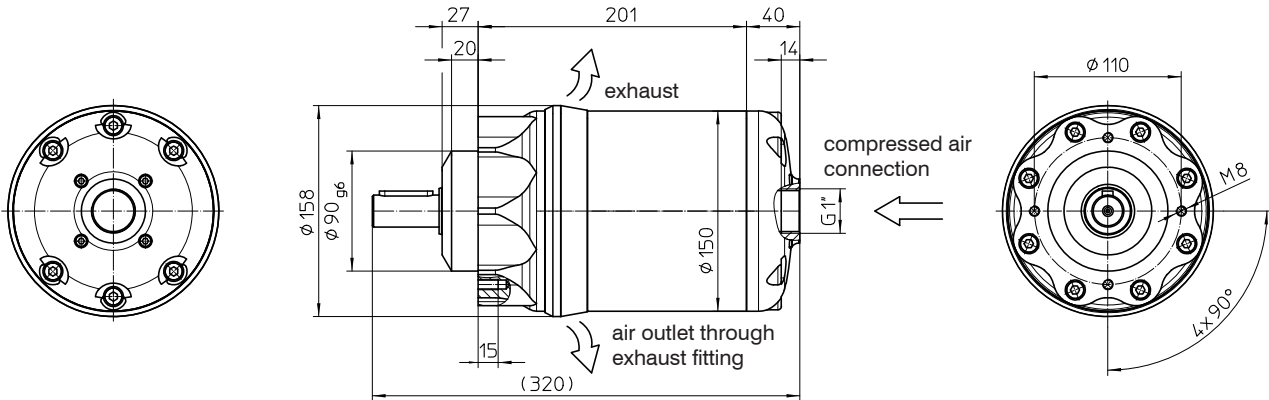

Output shaft: Cylindrical with feather key Z24 / Z28 to DIN 6885

Control: **PU** two directions of motor
PU1 two additional measurements and pulse connections

weight: 26 kg

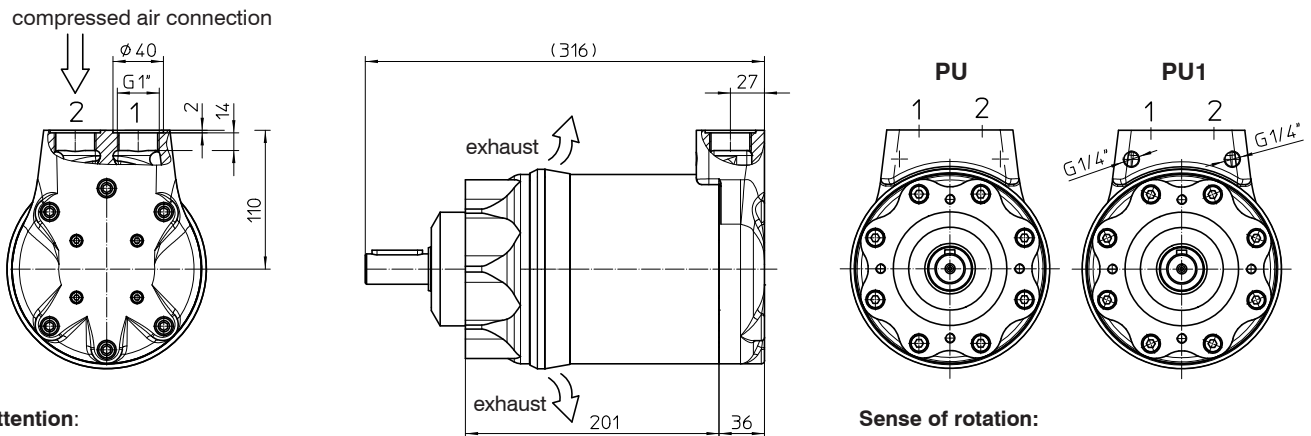

Attention:
By pressurization of connection 1 or 2 exhaust will be dissipate by 2 bzw. 1. The ports may not be closed.

Sense of rotation:
By viewing onto the output shaft- front surface
pressure connection at 1: anticlockwise
pressure connection at 2: clockwise

Output shaft: Cylindrical with feather key Z24 / Z28 to DIN 6885

Control: **PF** two direction of motor with locking position

weight: 29 kg

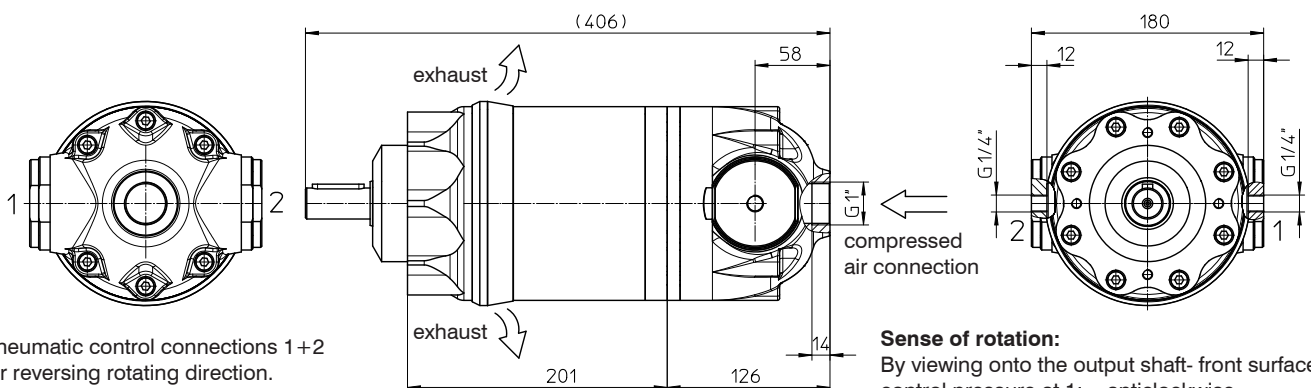

Pneumatic control connections 1+2 for reversing rotating direction. Pressureless: Motor stands still (integrated seat valve is closed).

Sense of rotation:
By viewing onto the output shaft- front surface
control pressure at 1: anticlockwise
control pressure at 2: clockwise
No control pressure: locking position



Output shaft: Cylindrical with feather key Z24 / Z28 to DIN 6885

Control: **EL** one direction of motor, anticlockwise
ER one direction of motor, clockwise

weight: 23,5 kg

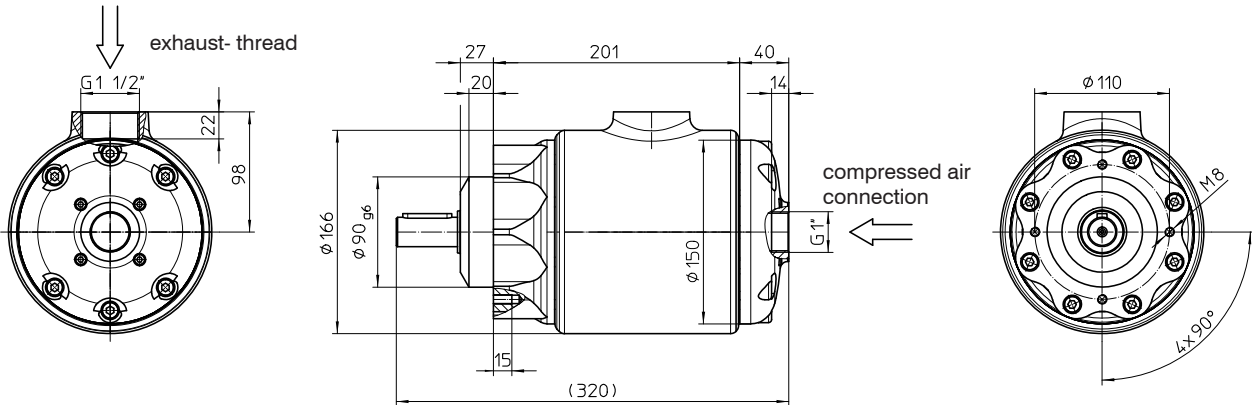

Output shaft: Cylindrical with feather key Z24 / Z28 to DIN 6885

Control: **PU** two direction of motor
PU1 two additional measurements and pulse connections

weight: 27 kg

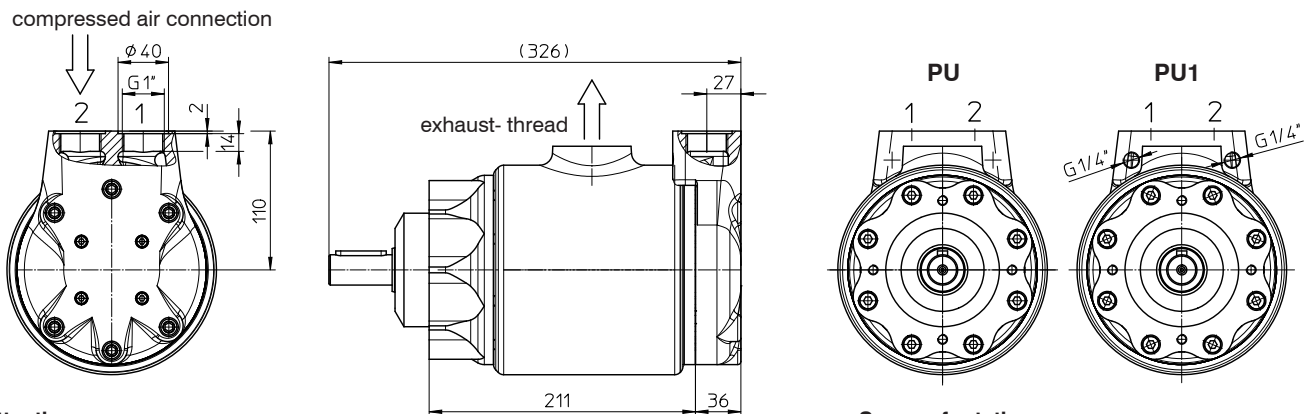

Attention:
BY pressurization of connection 1 or 2
exhaust will be dissipate by 2 bzw. 1.
The ports may not be closed.

Sense of rotation:
By viewing onto the output shaft- front surface
pressure connection at 1: anticlockwise
pressure connection at 2: clockwise

Output shaft: Cylindrical with feather key Z24 / Z28 to DIN 6885

Control: **PF** two direction of motor with locking position

weight: 30 kg

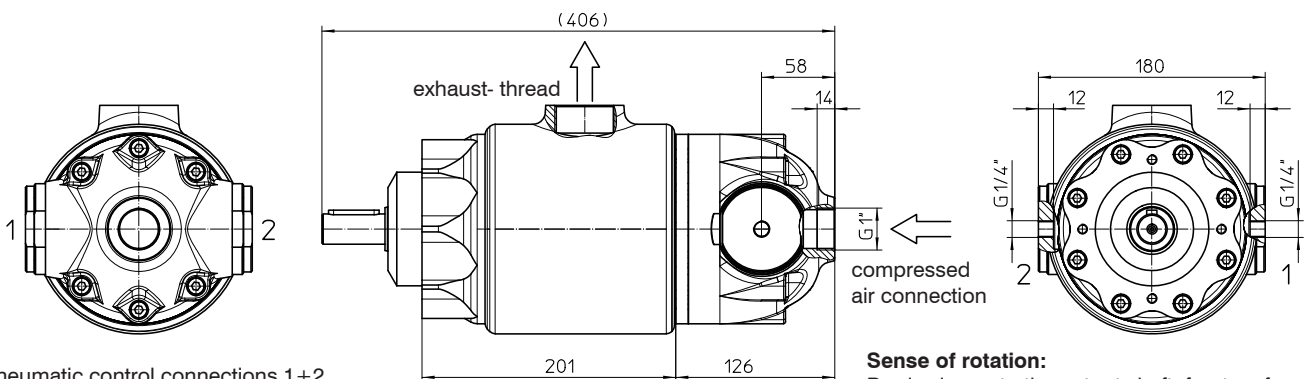

Pneumatic control connections 1+2
for reversing rotating direction.
Pressureless: Motor stands still
(integrated seat valve is closed).

Sense of rotation:
By viewing onto the output shaft- front surface
control pressure at 1: anticlockwise
control pressure at 2: clockwise
No control pressure: locking position



Basic version with exhaust fitting

weight: 29 kg

Output shaft: Cylindrical with feather key Z24 / Z28 to DIN 6885

Control: **ML** two directions at hand lever arrangement left und view onto the air connection.
MR two directions at hand lever arrangement right und view onto the air connection.

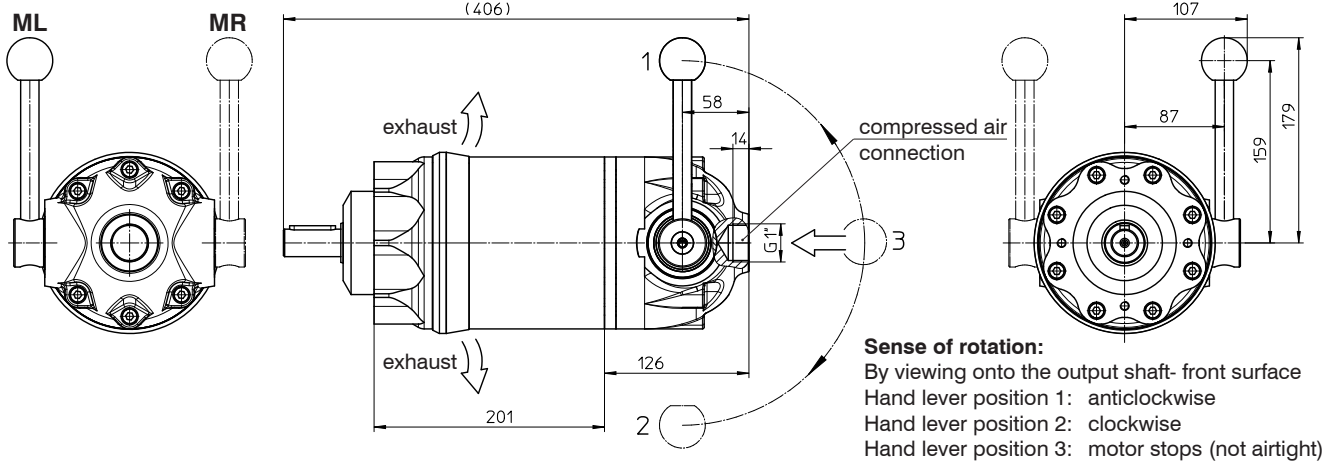

Basic version with exhaust thread, closed implementation „W“

weight: 30 kg

Output shaft: Cylindrical with feather key Z24 / Z28 to DIN 6885

Control: **ML** two directions at hand lever arrangement left und view onto the air connection.
MR two directions at hand lever arrangement right und view onto the air connection.

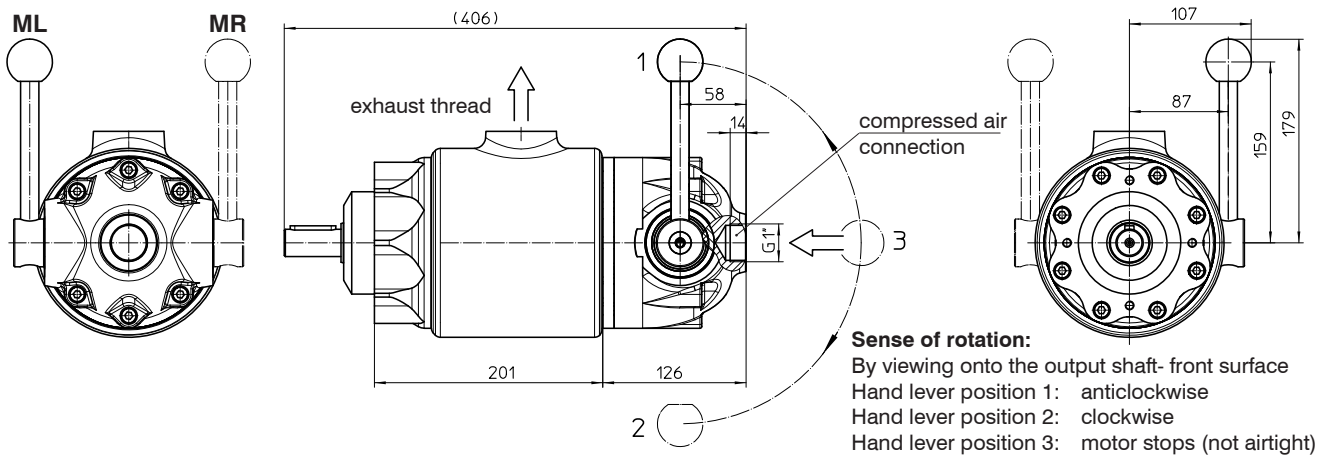

Output shaft implementation

feather key Z24 to DIN6885 A8x7x40

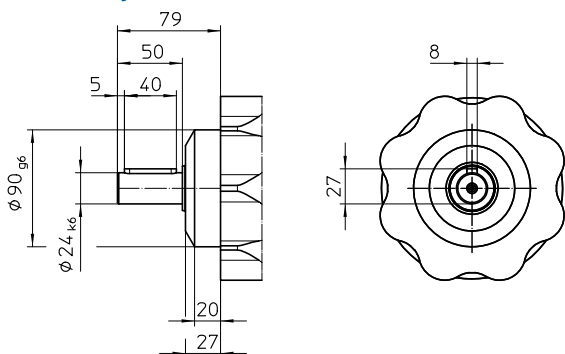

feather key Z28 to DIN6885 A8x7x50

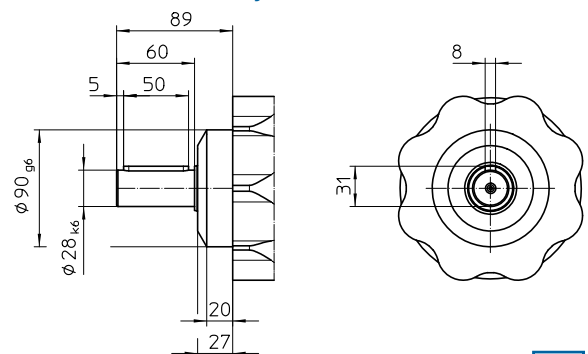

Commissioning and Maintenance Manual look catalog page Nr.: 02.000.087AD

Pressure medium: Compressed air if the compressed air is damped, we recommend to use an oiler!
Nitrogen, natural gas etc. in case of order please indicate the medium!

Mounting position: Any

Sense of rotation: By viewing onto the output shaft, see information in the data sheet!

Control typ: **EL / ER** : A rotation direction is given by a company (EL- simply anticlockwise / ER- simply clockwise).
PF : With integrated seat valves according to control $p = 3-10$ bar, for anticlockwise / clockwise and locking position. By relieving control pressure, automatic locking position.

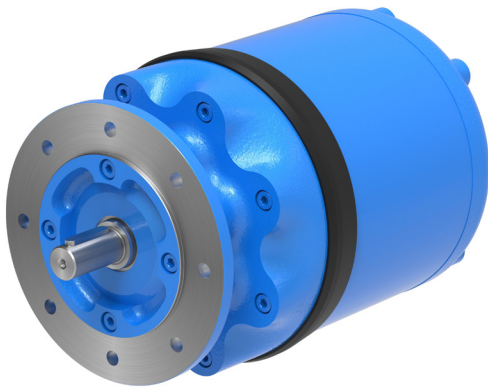

nominal pressure	$p_N = 6$	bar
max. operating pressure	$p_{max} = 10$	bar
nominal speed	$n_N = 3000$	min^{-1}
max. speed	$n_{max} = 4000$	min^{-1}

Technical data at $n=3000 min^{-1}$; $p=6 bar$

nominal air consumption	$Q_{nom} = 15$	Nm^3/min
nominal torque	$T_N = 35$	Nm
nominal power	$P_N = 11$	kW

The technical data relates to the unthrottled motor, that means without mounted exhaust air throttle, or silencer!

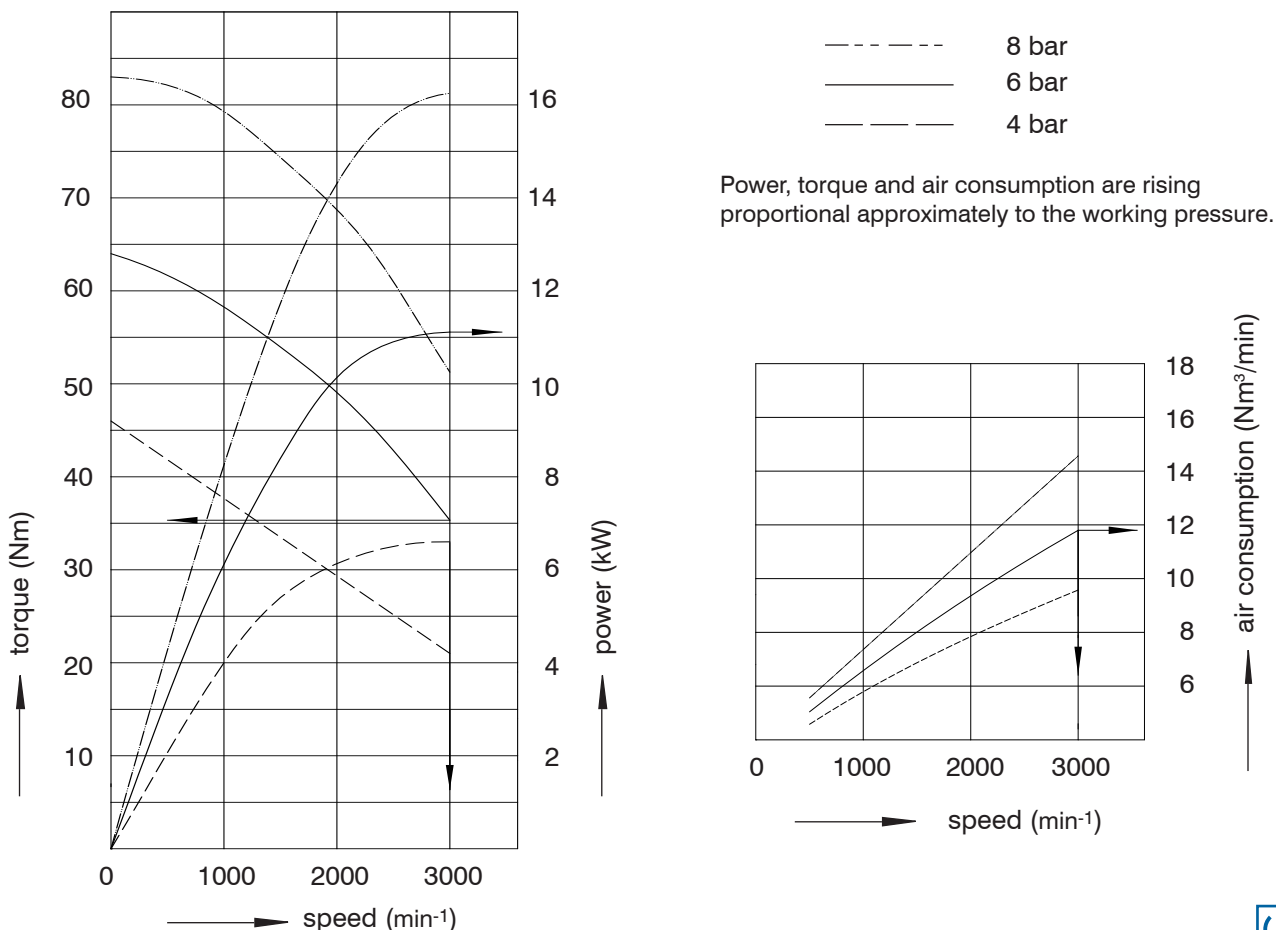

Output shaft: Cylindrical with feather key Z24 / Z28 to DIN 6885

Control: **EL** one direction of motor, anticlockwise
ER one direction of motor, clockwise

weight: 42 kg

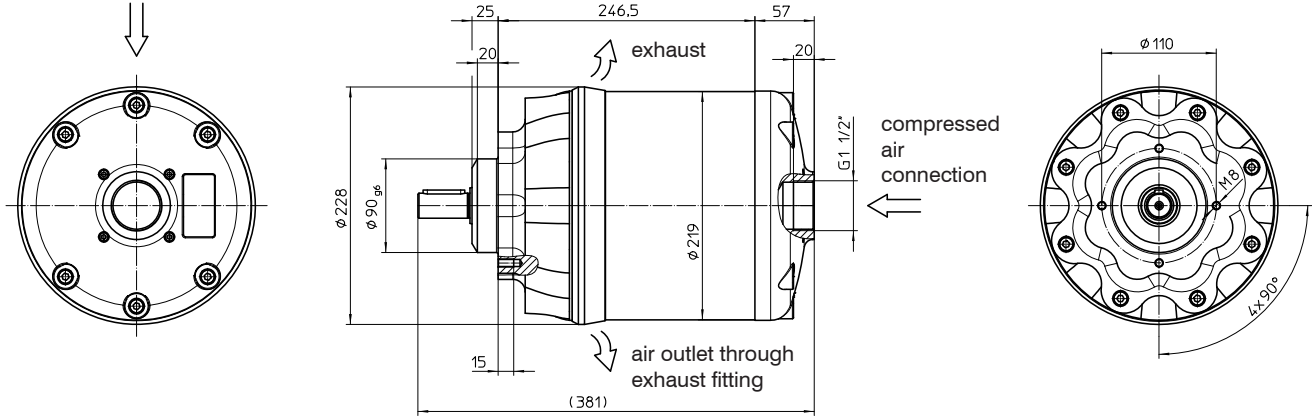

Output shaft: Cylindrical with feather key Z24 / Z28 to DIN 6885

Control: **PF** two direction of motor with locking position

weight: 60 kg

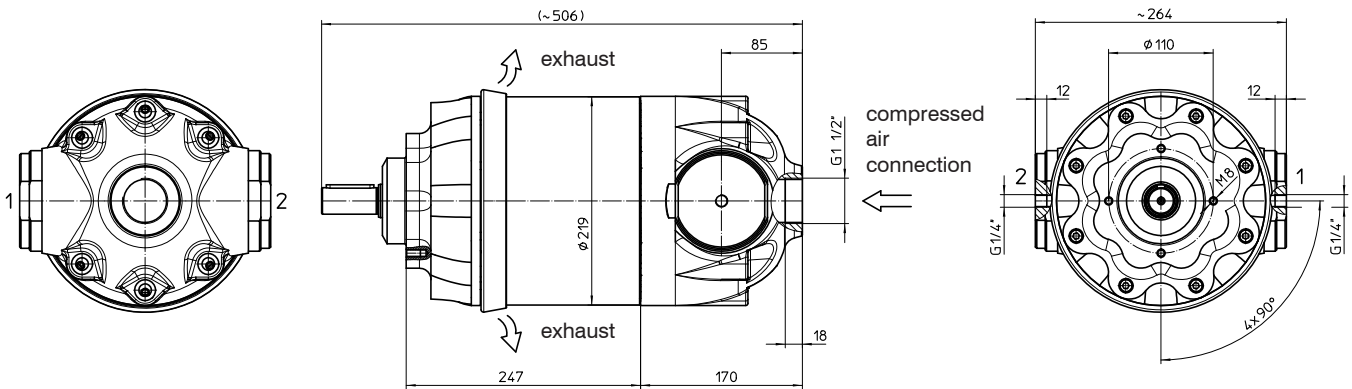

Pneumatic control connections 1+2 for reversing rotating direction.
Pressureless: Motor stands still (integrated seat valve is closed).

Sense of rotation:
By viewing onto the output shaft- front surface
control pressure at 1: anticlockwise
control pressure at 2: clockwise
No control pressure: locking position

Output shaft implementation

feather key Z24 to DIN6885 A8x7x40

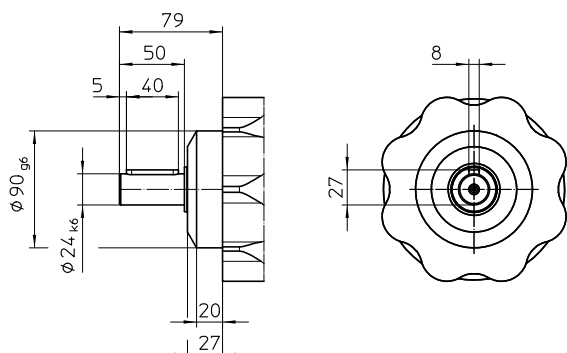

feather key Z28 to DIN6885 A8x7x50

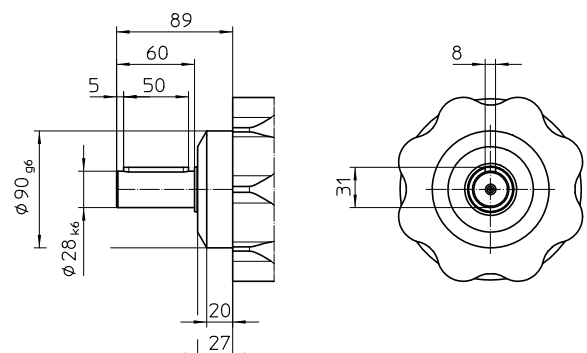

Ordering information for silencer: silencer G1 1/2: **20.5070.0111**

Technical data: nominal pressure: $p_n = 6 \text{ bar}$ weight: $m = 2,5 \text{ kg}$ thread: G1 1/2
 temperature range: $-10 \text{ °C bis } +150 \text{ °C}$ any mounting position multi-chamber system DBP

This silencer combines all requirements of a noise reducer.

- 1) high exhaust volume
- 2) short bleeding time
- 3) big sound absorption

The case consists of enameled steel sheet, the perforated sheet is galvanised. The polyester felt is resistant to age.

The silencer is water- and oil- resistant.

When using a silencer, in combination with the motor version „PU“, please consult the technical office.

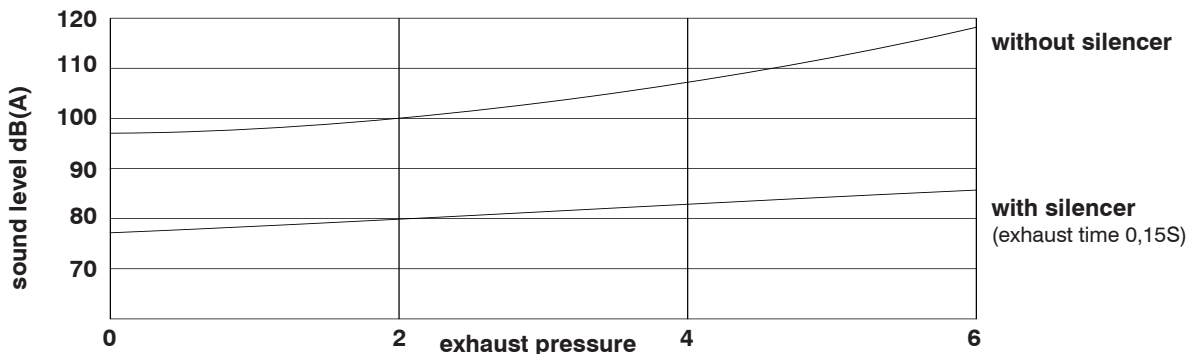
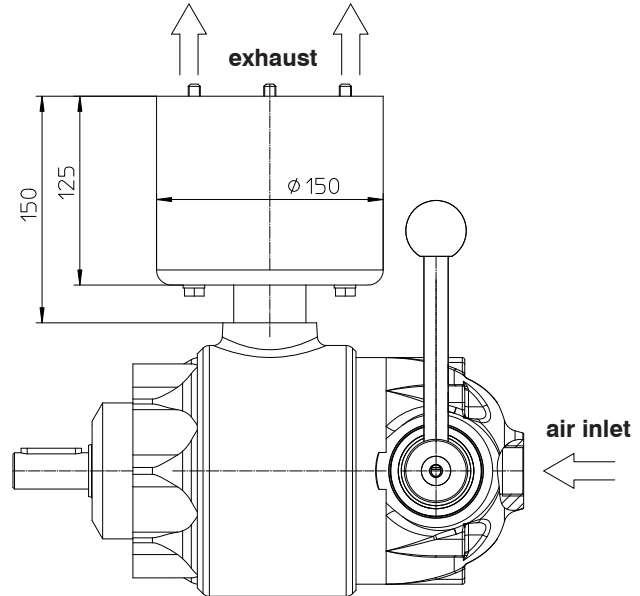

Sound measurement when bleeding a volume of 6 dm^3 at a distance of 1,5 m.

Ordering information for exhaust throttle: exhaust throttling com. **93.0000.0024**

The ordering number includes:

1 exhaust throttle NG 30	80.4121.3010
1 double nipple G11/2-G11/2	18.1070.1212
2 gasket A48x55 DIN7603 CU	18.11.60.1169

The exhaust throttle cannot be ordered in the version „PU“.

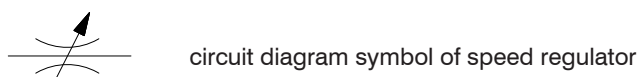

The throttling is made in both directions of flow. The pressure air flows through lateral holes to the throttling point. The throttling point occurs between the housing and the adjustable sleeve. By rotating the sleeve, the cross section of the throttle point is infinitely variable.

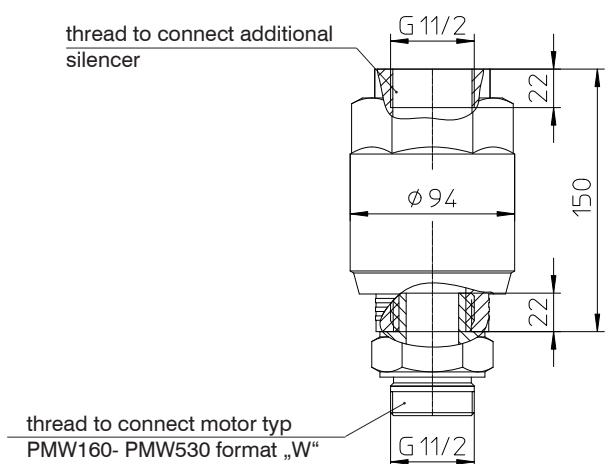

Further accessories, for example **dirt trap**, **ball valve** ... can be found in the accessories catalog **LM1-009DE**.



Drive-off flange: Flange dimension to IEC72 part 7 (electric-motor) DIN 42948.

A200 size 80/90S/90L
A350 size 160M/160L

A250 size 100L/112M
B14 size 71

A300 size 132S/132M
B14k size 90L/(IMV18;IMV19)

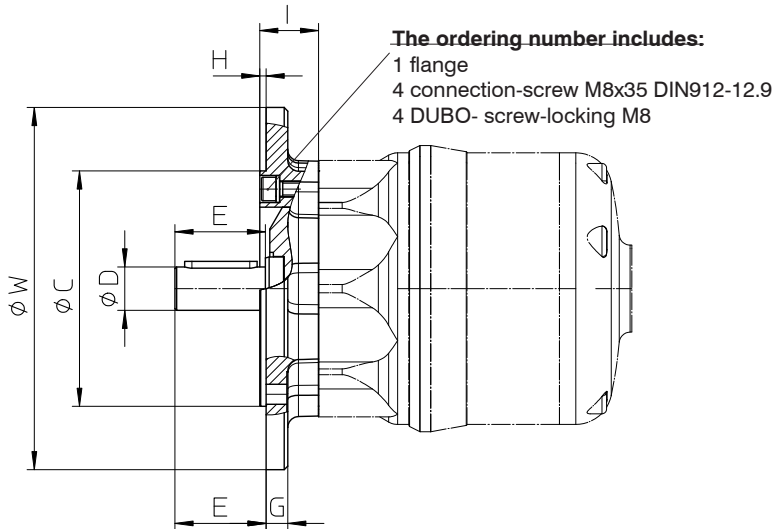

The ordering number includes:
1 flange
4 connection-screw M8x35 DIN912-12.9
4 DUBO- screw-locking M8

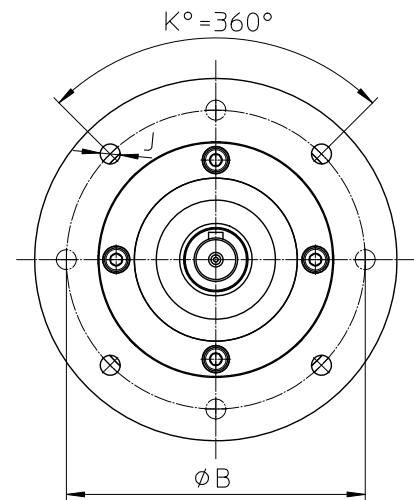

order nr.	flange	B	C	D	E	G	H	I	J	K	W	weight
12.2000.04	A200	ø 165	ø 130g6	ø 24 ø 28	50 60	12	3,5	32,5	ø 11	8x 45°	ø 200	3 kg
12.3000.04	A250	ø 215	ø 180g6	ø 24 ø 28	50 60	12	4	33	ø 13,5	8x 45°	ø 250	3,5 kg
12.3000.14	A300	ø 265	ø 230g6	ø 24 ø 28	50 60	12	4	33	ø 13,5	4x 90°	ø 300	4 kg
12.3000.24	A350	ø 300	ø 250g6	ø 24 ø 28	50 60	12	5	34	ø 17,5	4x 90°	ø 350	4,5 kg
12.3000.34	B14	ø 130	ø 110g6	ø 24 ø 28	50 60	10	3,5	33	thread stud hole M8x14,19 deep	4x 90°	ø 160	2,5 kg
12.3000.35	B14k	ø 115	ø 95g6	ø 24 ø 28	50 60	10	3,5	33	thread stud hole M8x14,19 deep	4x 90°	ø 140	2,5 kg

Output-side / foot: The developed foot for pneumatic motors, corresponds to the IEC Norm, elec. motor, installation size B3 100L. Ordering information: foot „F“, product no.: 12.2000.14 weight: 4,5 kg

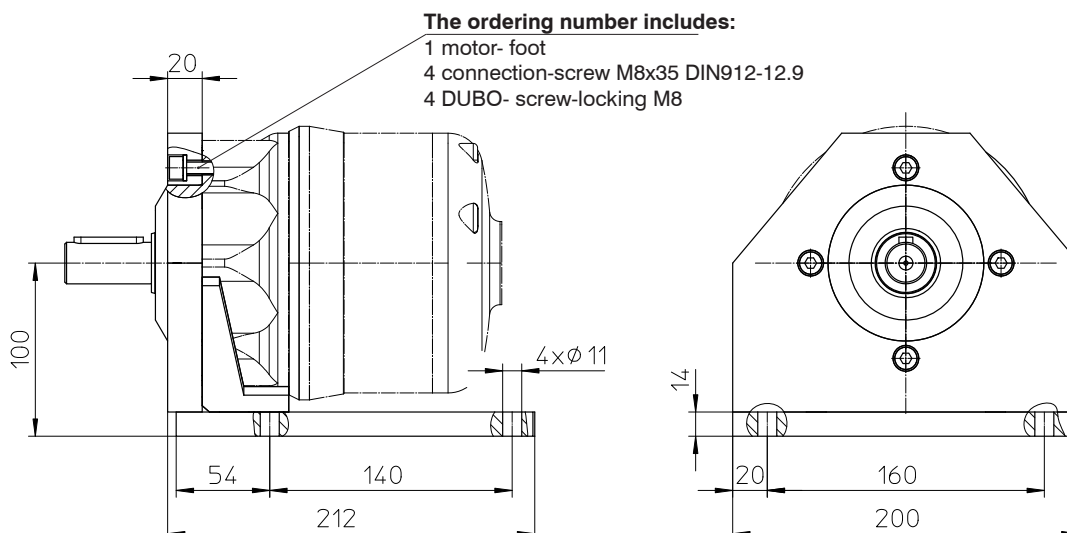

The ordering number includes:
1 motor-foot
4 connection-screw M8x35 DIN912-12.9
4 DUBO- screw-locking M8



The pressure spring multiple disk brake works as a holding brake and can be released with working pressure from 2-10 bar at control connection G1/4.

The brake output flange A200 corresponds to DIN42948.

The air should be filtered and provided with max. 1 - 3 drops oil per m³ working air.

Ordering information: Pressure spring multiple disk brake **LB42A200**, offer nr. **12.1720.29**
 (The pneumatic- motor fixing material belongs to extent of delivery.)

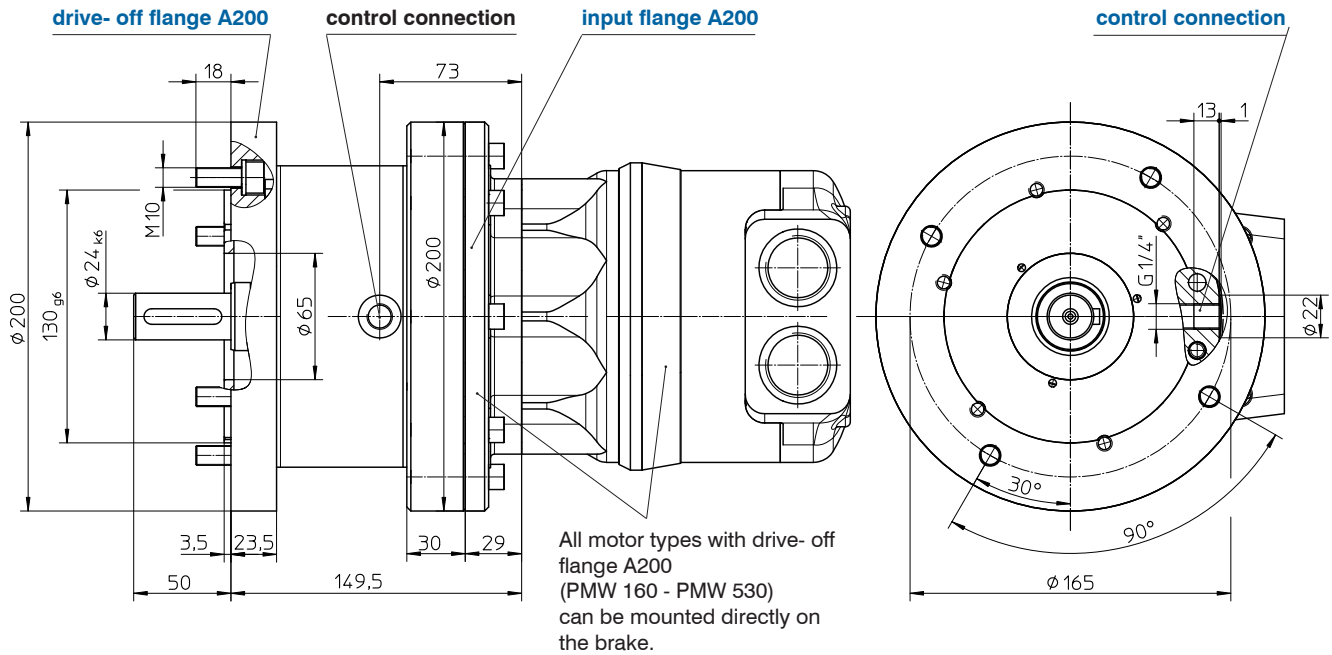

Operating mode: The spring force creates the required axial pressure for the holding torque. The opening of the brake is done by the control connection. Required pressure 2 - 10 bar. The max. holding torque is reached only by unpressurized control connection.

Technical data:	medium	:	compressed air
	opening pressure	:	2 up to 10 bar
	brake lamellar	:	dry running
	static holding torque	:	42 Nm
	dynamic holding torque	:	33 Nm
	temperature range	:	up to 90°C
	circuit- response- time	:	50 - 70 ms (depends on the reaction time of the control valve)
	weight	:	~ 15 kg

Further brake torques on request.

Possible combination: PMW ...- brake ...- gear ...

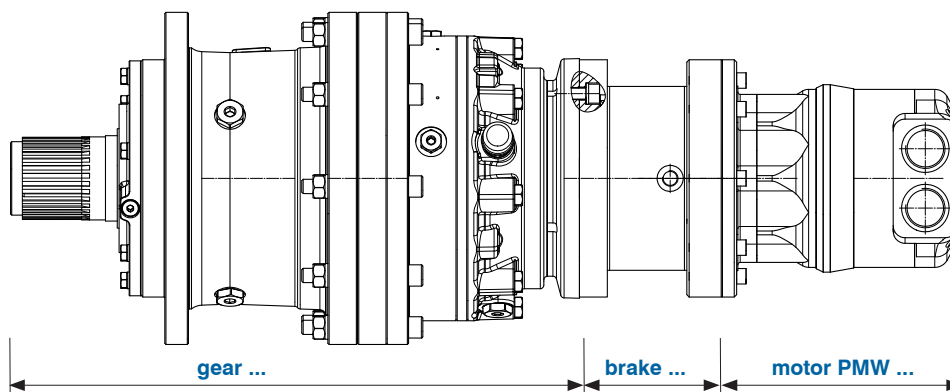

The pneumatic- gear- motors consist of pneumatic- motor design size PMW 160, PMW 250, PMW 400 or PMW 530 with flanged planetary gear 1, 2 or 3 -steps.

A downtime-, holding brake can additionally mounted between motor and gear.

Other gear types please inquire separately. (foot- gear, angle- gear, bevel-helical- gear, worm gear etc.).

The max. speed is specified in the tables and should not be exceeded. The speed limit / control is reached by the load or reached by an exhaust throttling /supply air throttling.

Horizontale mounting position (B3)

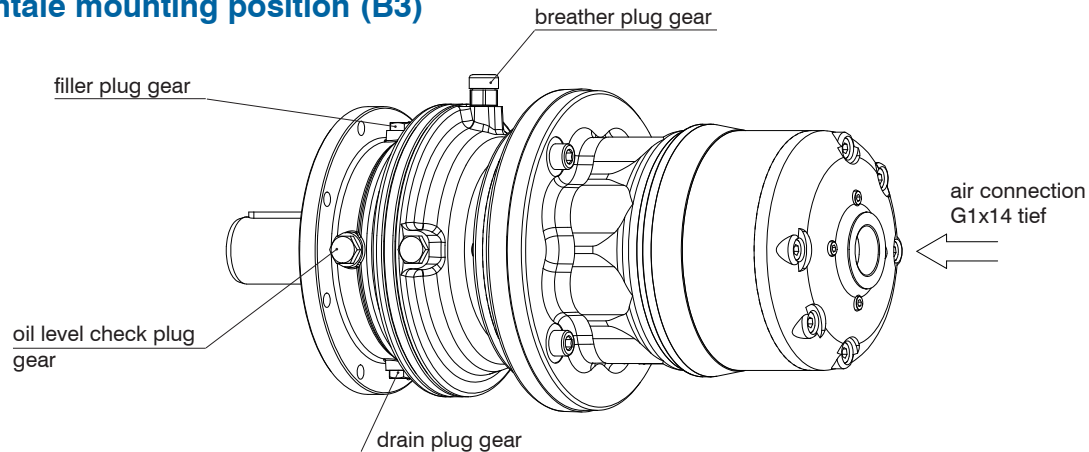

Vertical mounting position (V6)

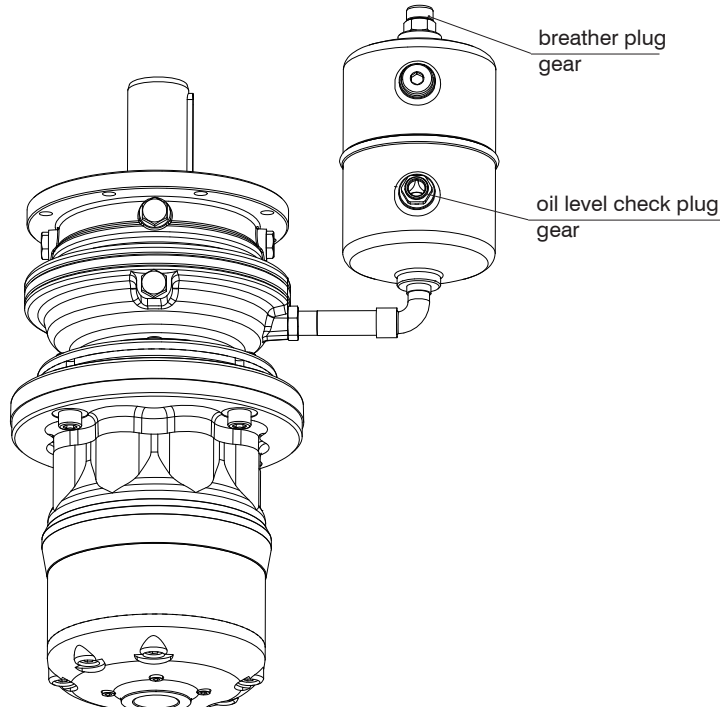

Vertical mounting position (V5)

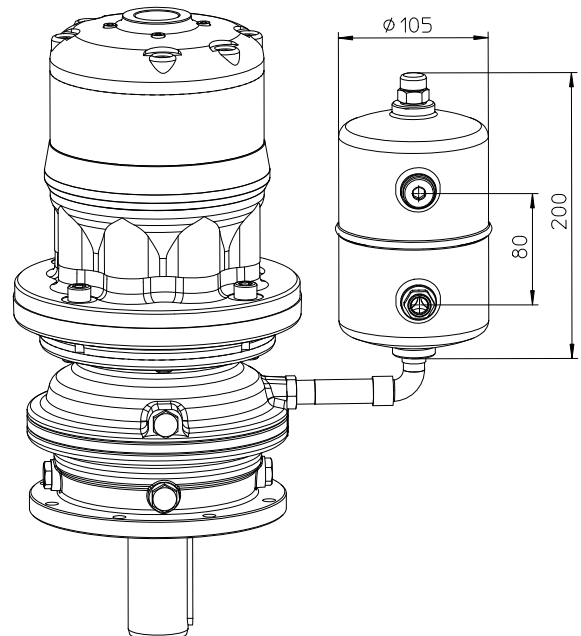

Please use gear oils with EP- addition, a minimum viscosity index of 95 and viscosity- class according to ISO- standard 3448, depending on the operating temperature. For standard applications with an operating temperature of +40°C up to +65°C, use viscosity class VG320 according to ISO 3448.

Before commissioning: fill with oil; note operating instructions.

Commissioning and maintenance instructions of gears, look at catalog no.: PG1-010D



Foot gear PD

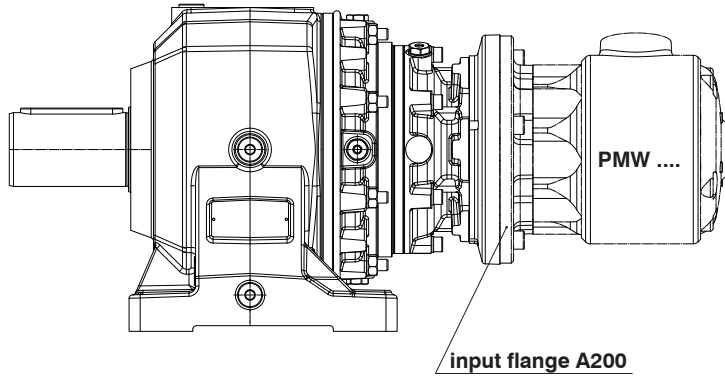

Angle gear EC

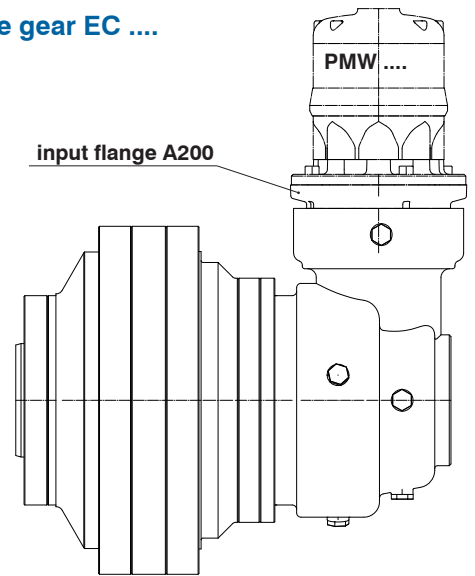

Angle-foot gear PDA

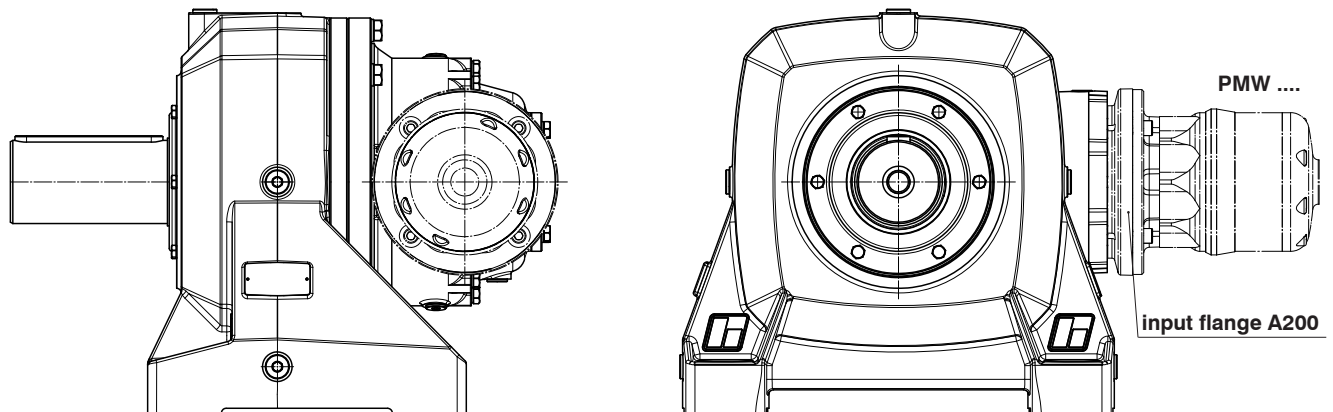

Bevel-helical- gear UMI

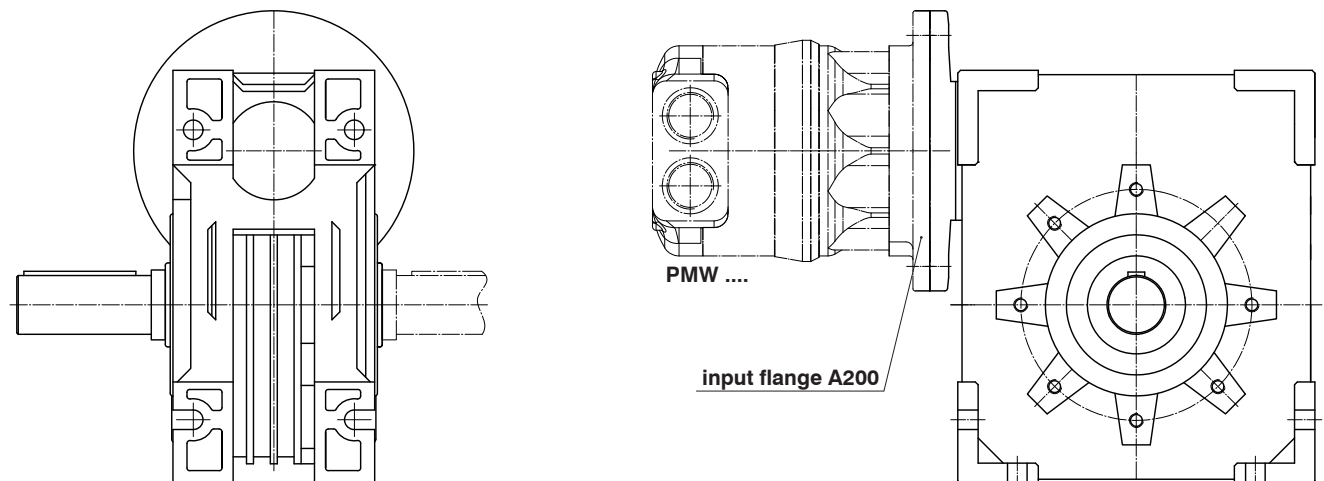

Specification: The gear housings are executed with a breather plug, an oil plug for oil control and an oil plug to change gear oil.

**shaft design
K/MRK**

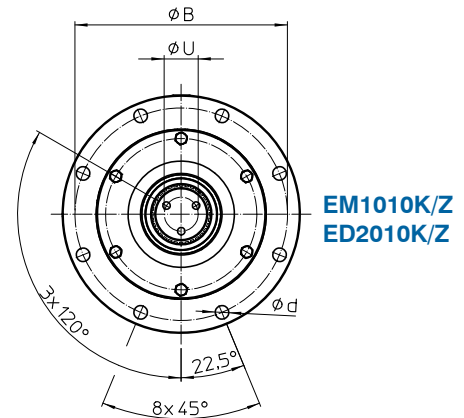
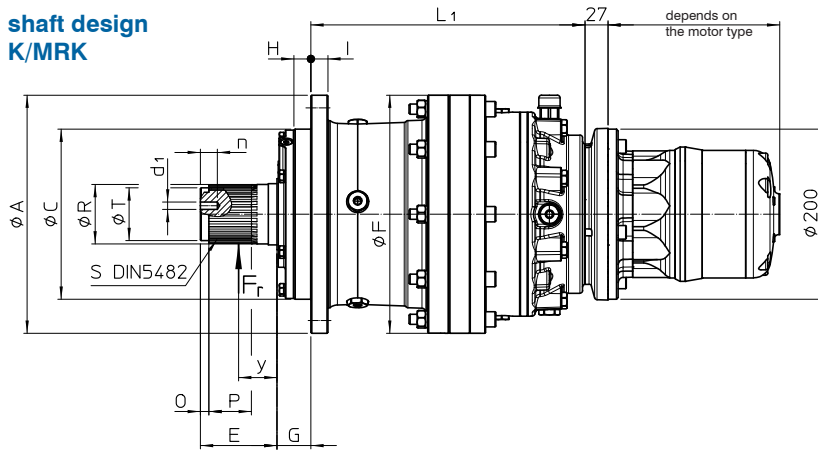

**shaft design
Z/MRZ**

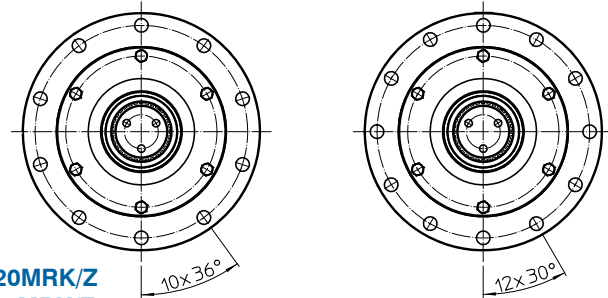
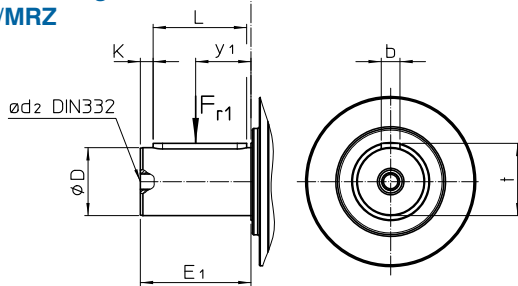

**ED2020MRK/Z
ET3020MRK/Z
ET3030MRK/Z
ET3045MRK/Z**

ET3065K/Z

typ	A	B	C _{f7}	D	E	E ₁	F	G	H	I	K	L	L ₁	O	P	Q	R _{f7}
PMW160..- EM1010K/Z..	180	165	110	42 _{k6}	55	82	183	7	6	13	6	70	127	5	30	48	42
PMW160..- ED2010K/Z..	180	165	110	42 _{k6}	55	82	183	7	6	13	6	70	167	5	30	48	42
PMW160..- ED2020MRK/Z..	220	195	150	65 _{m6}	68	105	240	15	5	16	7,5	90	245	8	38	58	60
PMW160..- ET3020MRK/Z..	220	195	150	65 _{m6}	68	105	240	15	5	16	7,5	90	284	8	38	58	60
PMW160..- ET3030MRK/Z..	220	195	150	65 _{m6}	68	105	240	15	5	16	7,5	90	284	8	38	58	60
PMW160..- ET3045MRK/Z..	220	195	150	65 _{m6}	68	105	240	15	5	16	7,5	90	312	8	38	58	60
PMW160..- ET3065MRK/Z..	280	250	200	80 _{m6}	90	130	280	40	15	20	10	110	375	10	50	80	72

typ	S	T _{f7}	U	b	d	d ₁	n	d ₂	t	y	y ₁	F _{r(N)}	F _{r1(N)}	kg
PMW160...- EM1010K/Z...	B40x36	35	24	12	9	M6	20	M16x36	45	27,5	41	10000	8000	39
PMW160...- ED2010K/Z...	B40x36	35	24	12	9	M6	20	M16x36	45	27,5	41	10000	8000	39
PMW160...- ED2020MRK/Z..	B58x53	50	32	18	14	M10	20	M20x42	69	34	52,5	30000	28000	56
PMW160...- ET3020MRK/Z..	B58x53	50	32	18	14	M10	20	M20x42	69	34	52,5	30000	28000	58
PMW160...- ET3030MRK/Z..	B58x53	50	32	18	14	M10	20	M20x42	69	34	52,5	30000	28000	66
PMW160...- ET3045MRK/Z..	B58x53	50	32	18	14	M10	20	M20x42	69	34	52,5	30000	28000	75
PMW160...- ET3065MRK/Z..	B70x64	62	40	22	16	M10	20	M20x42	85	45	65	70000	63000	104



Technical data:

nominal pressure	: p_{nom}	=	6 bar	nominal power	: P_{nom}	=	4,7 kW
max. operat. pressure:	p_{max}	=	10 bar	absolute air consumption	: Q_{abs}	=	6,0 Nm ³ /min
nominal speed	: n_{nom}	=	3000 U/min				

The technical data (nominal power and absolute air consumption) refer to nominal pressure, as well as nominal speed.

typ	i	start-torque		nominal torque (Nm)	safety factor (K_{nom})	speed	
		minimal (Nm)	maximal (Nm)			minimal (rpm)	maximal (rpm)
PMW250 ... - EM1010 ...	3,38	50	75	49	20,3	296	888
PMW250 ... - EM1010 ...	4,39	65	97	64	13,6	228	683
PMW250 ... - EM1010 ...	6,00	88	132	87	7,3	167	500
PMW250 ... - EM1010 ...	6,94	102	153	101	5,7	144	432
PMW250 ... - ED2010 ...	11,42	162	244	161	6,2	88	263
PMW250 ... - ED2010 ...	14,84	211	317	209	4,8	67	202
PMW250 ... - ED2010 ...	19,27	274	412	272	3,2	52	156
PMW250 ... - ED2010 ...	20,28	289	433	286	3,5	49	148
PMW250 ... - ED2010 ...	23,46	434	501	331	3,0	43	128
PMW250 ... - ED2020MR...	24,78	353	529	349	5,2	40	121
PMW250 ... - ED2020MR...	28,66	408	612	404	4,5	35	105
PMW250 ... - ED2020MR...	31,02	442	663	437	3,4	32	97
PMW250 ... - ED2020MR...	35,88	511	766	506	3,0	28	84
PMW250 ... - ED2020MR...	41,64	593	889	587	2,4	24	72
PMW250 ... - ED2030MR...	43,50	619	929	613	3,8	23	69
PMW250 ... - ET2030MR...	50,32	717	1075	710	3,2	20	59
PMW250 ... - ET3030MR...	59,06	822	1235	806	3,6	17	50
PMW250 ... - ET3030MR...	61,28	853	1280	836	4,1	16	48
PMW250 ... - ET3030MR...	70,98	988	1480	969	3,6	14	42
PMW250 ... - ET3030MR...	83,76	1165	1750	1145	3,0	12	35
PMW250 ... - ET3030MR...	89,03	1240	1860	1215	2,2	11	33
PMW250 ... - ET3045MR...	100,30	1400	2090	1370	2,7	10	29
PMW250 ... - ET3045MR...	108,60	1510	2270	1480	2,5	9	27
PMW250 ... - ET3045MR...	125,60	1750	2620	1715	2,2	8	23
PMW250 ... - ET3065MR...	134,30	1870	2800	1835	3,1	7	22
PMW250 ... - ET3065MR...	155,10	2160	3240	2120	2,6	6	19
PMW250 ... - ET3065MR...	180,00	2510	3760	2460	2,2	5	16
PMW250 ... - ET3090MR...	209,20	2910	4370	2860	2,4	4	14
PMW250 ... - ET3090MR...	219,70	3060	4590	3000	2,6	3	13

Note to the specified technical data:

- Start torque : The min. / max. start torque depends on to the tooth position of the rotor.
- Nominal torque : Nominal torque at nominal pressure and nominal torque.
- Safety factor : Gear safety factor according to gear torque und nominal torque.
- Speed min. : The minimal speed can be reached by throttling the motor.
- Speed max. : Maximal speed at gear output by nominal speed at the motor.



Specification: The gear housings are executed with a breather plug, an oil plug for oil control and an oil plug to change gear oil.

**shaft design
K/MRK**

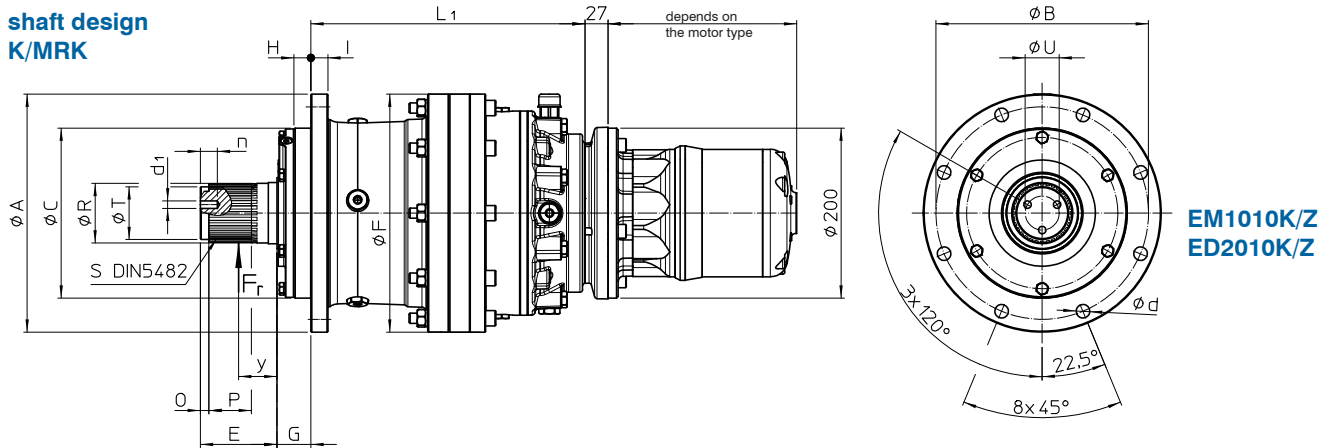

**EM1010K/Z
ED2010K/Z**

**shaft design
Z/MRZ**

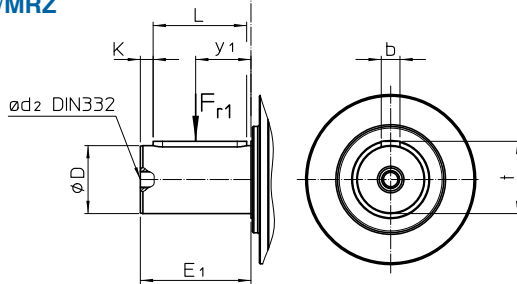

**ED2020MRK/Z
ED2030MRK/Z
ET3030MRK/Z
ET3045MRK/Z
ET3090MRK/Z**

ET3065MRK/Z

typ	A	B	C _{f7}	D	E	E ₁	F	G	H	I	K	L	L ₁	O	P	Q	R _{f7}
PMW250..- EM1010K/Z..	180	165	110	42 _{k6}	55	82	183	7	6	13	6	70	127	5	30	48	42
PMW250..- ED2010K/Z...	180	165	110	42 _{k6}	55	82	183	7	6	13	6	70	167	5	30	48	42
PMW250..- ED2020MRK/Z..	220	195	150	65 _{m6}	68	105	240	15	5	16	7,5	90	245	8	38	58	60
PMW250..- ED2030MRK/Z..	220	195	150	65 _{m6}	68	105	240	15	5	16	7,5	90	245	8	38	58	60
PMW250..- ET3030MRK/Z..	220	195	150	65 _{m6}	68	105	240	15	5	16	7,5	90	284	8	38	58	60
PMW250..- ET3045MRK/Z..	220	195	150	65 _{m6}	68	105	240	15	5	16	7,5	90	312	8	38	58	60
PMW250..- ET3065MRK/Z..	280	250	200	80 _{m6}	90	130	280	40	15	20	10	110	375	10	50	80	72
PMW250..- ET3090MRK/Z..	325	295	230	90 _{m6}	90	170	355	36	5	25	5	160	376	10	50	80	85

typ	S	T _{f7}	U	b	d	d ₁	n	d ₂	t	y	y ₁	F _{r(N)}	F _{r1(N)}	kg
PMW250..- EM1010K/Z..	B40x36	35	24	12	9	M6	20	M16x36	45	27,5	41	10000	8000	39
PMW250..- ED2010K/Z..	B40x36	35	24	12	9	M6	20	M16x36	45	27,5	41	10000	8000	39
PMW250..- ED2020MRK/Z..	B58x53	50	32	18	14	M10	20	M20x42	69	34	52,5	30000	28000	56
PMW250..- ED2030MRK/Z..	B58x53	50	32	18	14	M10	20	M20x42	69	34	52,5	30000	28000	58
PMW250..- ET3030MRK/Z..	B58x53	50	32	18	14	M10	20	M20x42	69	34	52,5	30000	28000	66
PMW250..- ET3045MRK/Z..	B58x53	50	32	18	14	M10	20	M20x42	69	34	52,5	30000	28000	75
PMW250..- ET3065MRK/Z..	B70x64	62	40	22	16	M10	20	M20x42	85	45	65	70000	63000	104
PMW250..- ET3090MRK/Z..	B80x74	70	45	25	18	M10	25	M24x50	95	45	85	70000	58000	143



Technical data:

nominal pressure : p_{nom} = 6 bar
 max. operat. pressure: p_{max} = 10 bar
 nominal speed : n_{nom} = 3000 U/min
 nominal power : P_{nom} = 6,9 kW
 absolute air consumption : Q_{abs} = 8,4 Nm³/min

The technical data (nominal power and absolute air consumption) refer to nominal pressure, as well as nominal speed.

typ	i	start-torque		nominal torque (Nm)	safety factor (K_{nom})	speed	
		minimal (Nm)	maximal (Nm)			minimal (rpm)	maximal (rpm)
PMW400 ... - EM1010 ...	3,38	72	106	72	13,9	296	888
PMW400 ... - EM1010 ...	4,39	93	137	94	9,3	228	683
PMW400 ... - EM1010 ...	6,00	127	188	128	5,0	167	500
PMW400 ... - EM1010 ...	6,94	147	217	148	3,9	144	432
PMW400 ... - ED2010 ...	11,42	250	370	252	4,0	88	263
PMW400 ... - ED2020MR...	13,52	277	400	280	6,4	74	221
PMW400 ... - ED2020MR...	15,37	315	465	318	6,3	65	195
PMW400 ... - ED2020MR...	18,13	371	549	375	4,8	56	165
PMW400 ... - ED2020MR...	21,00	430	635	434	4,6	48	142
PMW400 ... - ED2020MR...	22,70	465	687	469	3,2	44	132
PMW400 ... - ED2020MR...	24,78	507	750	512	3,5	41	121
PMW400 ... - ED2020MR...	28,66	587	867	593	3,0	35	104
PMW400 ... - ED2020MR...	31,02	635	939	641	2,3	33	96
PMW400 ... - ED2030MR...	36,00	737	1090	744	3,6	28	83
PMW400 ... - ED2030MR...	41,64	852	1260	861	3,1	24	72
PMW400 ... - ED2030MR...	43,50	890	1315	890	2,6	23	69
PMW400 ... - ED2030MR...	50,32	1030	1520	1040	2,2	20	59
PMW400 ... - ET3030MR...	59,06	1180	1745	1180	2,5	17	50
PMW400 ... - ET3045MR...	63,46	1270	1875	1270	2,9	16	47
PMW400 ... - ET3045MR...	73,50	1470	2170	1470	2,5	14	40
PMW400 ... - ET3045MR...	79,44	1570	2350	1590	2,3	13	37
PMW400 ... - ET3065MR...	90,93	1820	2690	1820	3,1	11	33
PMW400 ... - ET3065MR...	98,27	1970	2910	1960	2,9	10	30
PMW400 ... - ET3065MR...	110,60	2210	3270	2210	2,6	9	27
PMW400 ... - ET3090MR...	126,60	2530	3740	2530	3,6	8	24
PMW400 ... - ET3090MR...	146,90	2940	4350	2940	3,1	7	20
PMW400 ... - ET3090MR...	152,90	3060	4520	3060	2,9	6	18
PMW400 ... - ET3090MR...	177,50	3550	5250	3550	2,5	5	16

Note to the specified technical data:

- Start torque : The min. / max. start torque depends on to the tooth position of the rotor.
- Nominal torque : Nominal torque at nominal pressure and nominal torque.
- Safety factor : Gear safety factor according to gear torque und nominal torque.
- Speed min. : The minimal speed can be reached by throttling the motor.
- Speed max. : Maximal speed at gear output by nominal speed at the motor.



Specification: The gear housings are executed with a breather plug, an oil plug for oil control and an oil plug to change gear oil.

**shaft design
K/MRK**

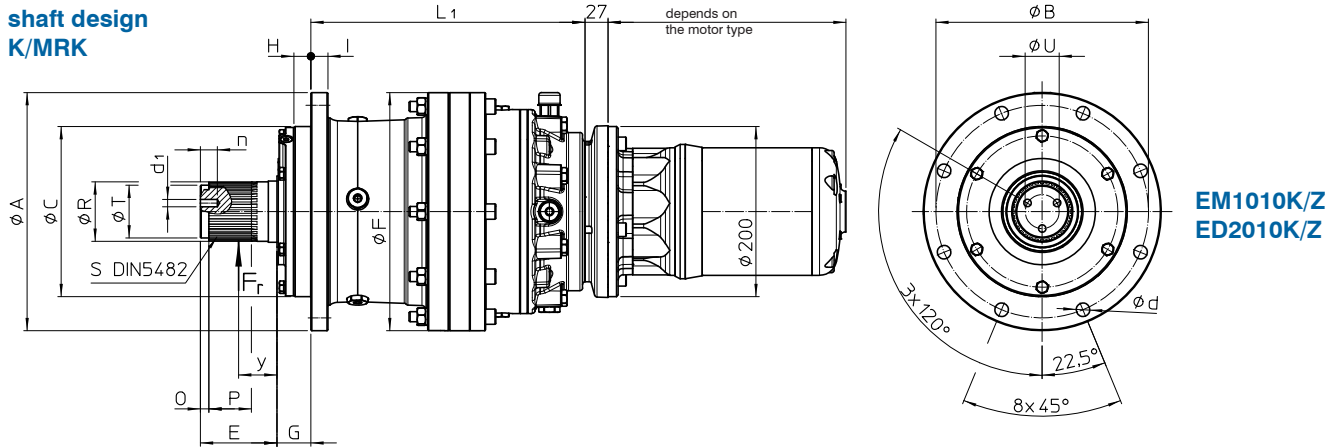

**EM1010K/Z
ED2010K/Z**

**shaft design
Z/MRZ**

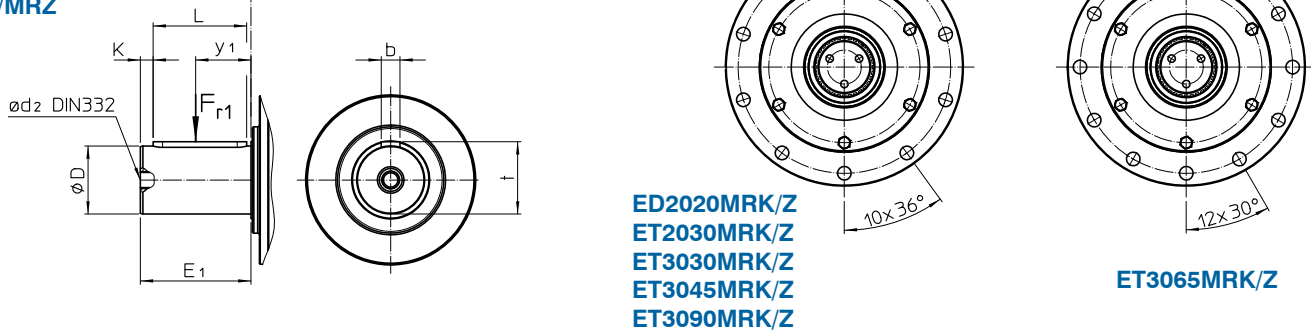

**ED2020MRK/Z
ET2030MRK/Z
ET3030MRK/Z
ET3045MRK/Z
ET3090MRK/Z**

ET3065MRK/Z

typ	A	B	C _{f7}	D	E	E ₁	F	G	H	I	K	L	L ₁	O	P	Q	R _{f7}
PMW400..- EM1010K/Z..	180	165	110	42 _{k6}	55	82	183	7	6	13	6	70	127	5	30	48	42
PMW400..- ED2010K/Z..	180	165	110	42 _{k6}	55	82	183	7	6	13	6	70	167	5	30	48	42
PMW400..- ED2020MRK/Z..	220	195	150	65 _{m6}	68	105	240	15	5	16	7,5	90	245	8	38	58	60
PMW400..- ED2030MRK/Z..	220	195	150	65 _{m6}	68	105	240	15	5	16	7,5	90	245	8	38	58	60
PMW400..- ET3030MRK/Z..	220	195	150	65 _{m6}	68	105	240	15	5	16	7,5	90	284	8	38	58	60
PMW400..- ET3045MRK/Z..	220	195	150	65 _{m6}	68	105	240	15	5	16	7,5	90	312	8	38	58	60
PMW400..- ET3065MRK/Z..	280	250	200	80 _{m6}	90	130	280	40	15	20	10	110	375	10	50	80	72
PMW400..- ET3090MRK/Z..	325	295	230	90 _{m6}	90	170	355	36	5	25	5	160	376	10	50	80	85

typ	S	T _{f7}	U	b	d	d ₁	n	d ₂	t	y	y ₁	F _{r(N)}	F _{r1(N)}	kg
PMW400..- EM1010K/Z..	B40x36	35	24	12	9	M6	20	M16x36	45	27,5	41	10000	8000	39
PMW400..- ED2010K/Z..	B40x36	35	24	12	9	M6	20	M16x36	45	27,5	41	10000	8000	39
PMW400..- ED2020MRK/Z..	B58x53	50	32	18	14	M10	20	M20x42	69	34	52,5	30000	28000	56
PMW400..- ED2030MRK/Z..	B58x53	50	32	18	14	M10	20	M20x42	69	34	52,5	30000	28000	58
PMW400..- ET3030MRK/Z..	B58x53	50	32	18	14	M10	20	M20x42	69	34	52,5	30000	28000	66
PMW400..- ET3045MRK/Z..	B58x53	50	32	18	14	M10	20	M20x42	69	34	52,5	30000	28000	75
PMW400..- ET3065MRK/Z..	B70x64	62	40	22	16	M10	20	M20x42	85	45	65	70000	63000	104
PMW400..- ET3090MRK/Z..	B80x74	70	45	25	18	M10	25	M24x50	95	45	85	70000	58000	143



Specification: The gear housings are executed with a breather plug, an oil plug for oil control and an oil plug to change gear oil.

**shaft design
K/MRK**

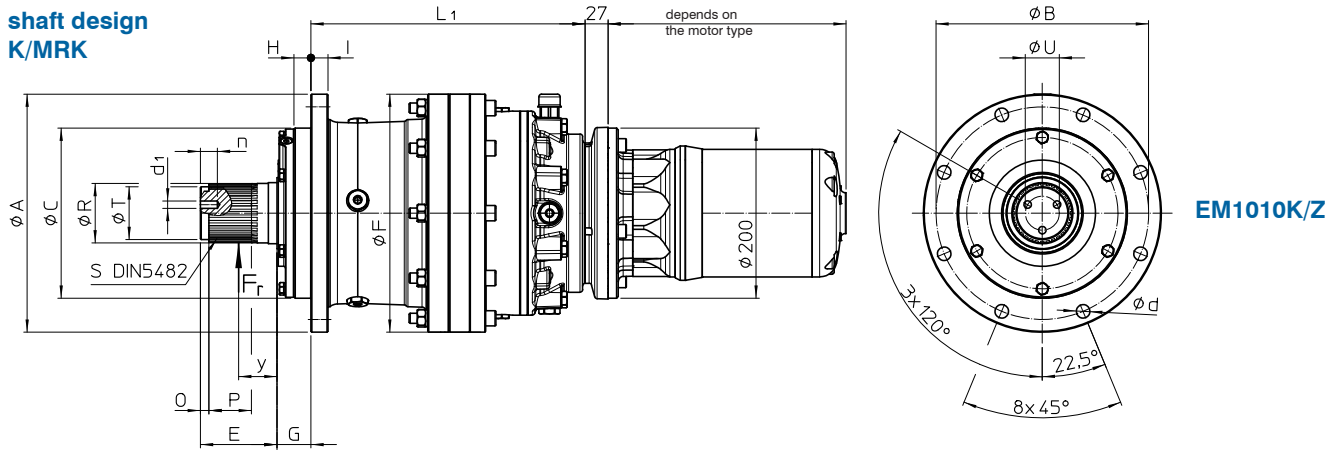

EM1010K/Z

**shaft design
Z/MRZ**

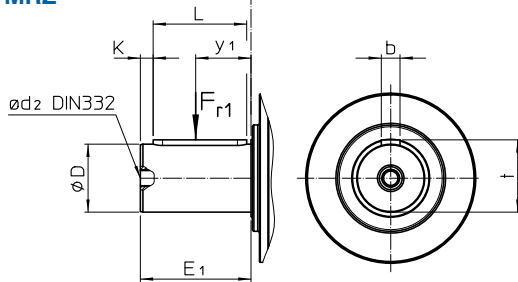

**ED2020MRK/Z
ET2030MRK/Z
ET3030MRK/Z
ET3045MRK/Z
ET3090MRK/Z**

ET3065MRK/Z

typ	A	B	C _{f7}	D	E	E ₁	F	G	H	I	K	L	L ₁	O	P	Q	R _{f7}
PMW530..- EM1010K/Z..	180	165	110	42 _{k6}	55	82	183	7	6	13	6	70	127	5	30	48	42
PMW530..- ED2020MRK/Z..	220	195	150	65 _{m6}	68	105	240	15	5	16	7,5	90	245	8	38	58	60
PMW530..- ED2030MRK/Z..	220	195	150	65 _{m6}	68	105	240	15	5	16	7,5	90	245	8	38	58	60
PMW530..- ED2045MRK/Z..	220	195	150	65 _{m6}	68	105	240	15	5	16	7,5	90	260	8	38	58	60
PMW530..- ET3045MRK/Z..	220	195	150	65 _{m6}	68	105	240	15	5	16	7,5	90	312	8	38	58	60
PMW530..- ET3065MRK/Z..	280	250	200	80 _{m6}	90	130	280	40	15	20	10	110	375	10	50	80	72
PMW530..- ET3090MRK/Z..	325	295	230	90 _{m6}	90	170	355	36	5	25	5	160	376	10	50	80	85

typ	S	T _{f7}	U	b	d	d ₁	n	d ₂	t	y	y ₁	F _{r(N)}	F _{r1(N)}	kg
PMW530..- EM1010K/Z..	B40x36	35	24	12	9	M6	20	M16x36	45	27,5	41	10000	8000	39
PMW530..- ED2020MRK/Z..	B58x53	50	32	18	14	M10	20	M20x42	69	34	52,5	30000	28000	56
PMW530..- ED2030MRK/Z..	B58x53	50	32	18	14	M10	20	M20x42	69	34	52,5	30000	28000	58
PMW530..- ED2045MRK/Z..	B58x53	50	32	18	14	M10	20	M20x42	69	34	52,5	30000	28000	75
PMW530..- ET3045MRK/Z..	B58x53	50	32	18	14	M10	20	M20x42	69	34	52,5	30000	28000	79
PMW530..- ET3065MRK/Z..	B70x64	62	40	22	16	M10	20	M20x42	85	45	65	70000	63000	104
PMW530..- ET3090MRK/Z..	B80x74	70	45	25	18	M10	25	M24x50	95	45	65	70000	58000	143



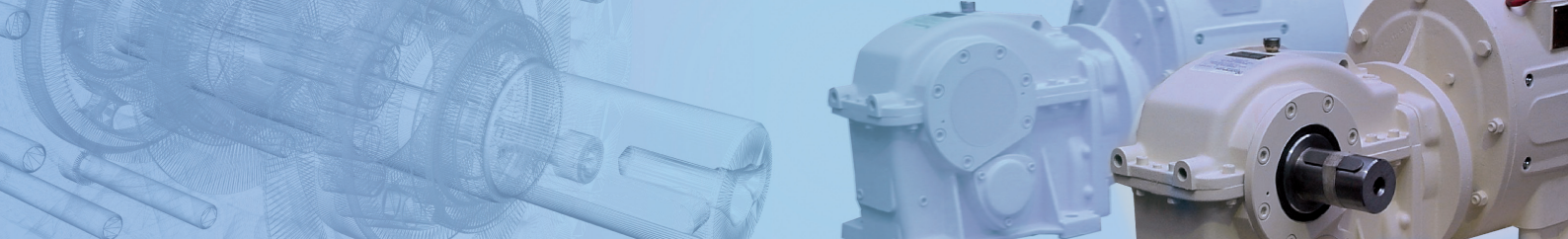

DÜSTERLOH has been developing fluid technology products for more than 100 years.

The drives, controls and hydraulic power units from Hattingen are appreciated throughout the world for their complete reliability; including under extreme conditions. The owner-managed company's own development and construction department and the wide range of products cater for distinctive flexibility and customer-orientation.

Products

- Hydraulic radial piston motors
- Hydraulic axial piston motors
- Pneumatic motors
- Pneumatic starters
- Hydraulic and pneumatic controls
- Hydraulic power units

Designing controls and hydraulic power units specific to the customer is our company's major strength. Vast product diversity is also available for standardized products.

Industrial areas of application

- Machine tools
- Smelting and rolling mill equipment
- Foundry machines
- Testing machines
- Shipbuilding (diesel engines)
- Offshore technology
- Printing and paper technology
- Vehicle construction
- Manipulators
- Environmental technology
- Mining equipment
- Materials handling equipment

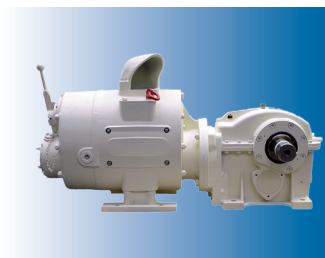

Düsterloh Fluidtechnik GmbH

Im Vogelsang 105
D-45527 Hattingen

Tel.: +49 2324 709-0
Fax: +49 2324 709-110



e-mail: info@duesterloh.de
Internet: www.duesterloh.de